



Genesee County Land Bank Authority

452 S. Saginaw St. 2nd Floor, Flint, MI 48502

Neighborhood Stabilization Program 2 (NSP2)

Invitation for Bids – General Contractor

2448 Thomas St., Flint, MI 48504

BID NUMBER: LB 11-025

Due Date: Monday, August 29, 2011 at 3:00 pm EST

As part of the Michigan NSP 2 Consortium, a partnership between:

Michigan State Housing Development Authority (MSHDA)

The City of Flint

Genesee County Land Bank Authority (GCLBA)



INVITATION FOR BIDS: 2448 THOMAS ST. – GENERAL CONTRACTOR

Overview

The Genesee County Land Bank Authority (GCLBA) is seeking sealed bids for the rehabilitation of 2448 Thomas St., Flint, MI 48504. This property is being rehabilitated as single-family residential homes to be sold to income eligible buyers under the Neighborhood Stabilization Program 2 (NSP2). The GCLBA has received NSP 2 grant funding from the MSHDA for this purpose. The NSP 2 funds are provided to MSHDA from the U.S. Department of Housing and Urban Development (HUD).

Sealed Bid Due Date

General contractors with qualifications and experience in renovation of single-family residential properties invited to submit sealed bids to the Genesee County Land Bank Authority, 452 S. Saginaw St., 2nd Floor, Flint, Michigan 48502 on or before **Monday, August 29, 2011 at 3:00 pm EST.** The outside of the envelope must be marked “**LB 11-025, Sealed Bid for 2448 Thomas St.**”

Bid Opening

The bid opening will be Monday, August 29, 2011 at 3:15 pm EST at the Genesee County Land Bank Authority, Conference Room, 452. S. Saginaw St., 2nd Floor, Flint, MI 48502 and is open to the public.

Mandatory Pre-bid Meeting and Walkthrough

A mandatory pre-bid meeting will take place at 2448 Thomas St., Flint, MI 48504 at 9:00 am on Friday, August 19th, 2011.

A mandatory walkthrough of property to be rehabilitated will follow at 2448 Thomas St., Flint, MI 48504 from 9:00 am to 10:00 am.

Bidders must be present at both the pre-bid meeting and the walkthrough in order to bid on this proposal.

Proposal Requirements/ Bidding Instructions

Bids must be sealed, the outside of the envelope must be marked “LB 11-025, Sealed Bid for 2448 Thomas St.” and contain the following:

1. Copy of a Valid State of Michigan Builders License
2. Copies of E.P.A. Renovator and Firm Certificates
3. Copy of Lead Abatement Contractor Certification
4. 2011 Certificate to do Business with Genesee County
5. City of Flint Section 3 Certification
6. Insurance Certificate including:
 - a. Worker’s Compensation
 - b. General Liability of \$2,000,000 for Bodily Injury and Property Damage
 - c. Genesee County Land Bank named as a Certificate Holder
7. Bid Guarantee Required at 5% of the bid amount if the contractor’s bid amount is over \$50,000
8. Subcontractor information form (attached)
9. Certification Form Note (attached)
10. Demonstration of Capacity Form (attached)
11. Typed or Inked Contractor Bid Form and Specifications (attached)

City of Flint Section 3 Certification

City of Flint Section 3 Certification is a requirement of this rehabilitation project. The lowest qualified bidder of this proposal will be given 10 business days from the bid opening to provide the Genesee County Land Bank with a Section 3 Certification from the City of Flint. Requirements for this are included in the bid package. Certified payroll will be required to accompany the monthly Section 3 forms to assure GCLBA that the Section 3 compliance is met. The Certified payroll will not be linked to Davis-Bacon wage rates. This is not a Davis- Bacon project.

Bid Acceptance

Bid proposals of more than 10% lower or 15% higher than the GCLBA cost estimate will be disqualified. The GCLBA anticipates immediately entering into a contract with the general contractor after all certification requirements have been provided and accepted. The contractor must be ready to begin work immediately upon receipt of the notice to proceed by the GCLBA.

Value Engineering

Value engineering may be used by the GCLBA after the contractor has been selected particularly in instances where a line item significantly varies from the specification writer’s estimate.

Method of Payment

Payment will be made for work items completed based on the accepted price per the contractors bid including any value engineering. GCLBA will provide payment for work items completed after invoice from the contractor, inspection and acceptance by GCLBA, submittal of Section 3 documentation, sworn statements and any lien waivers from the work items completed. The GCLBA will provide payment within 30 days of invoice with complete documentation as required by GCLBA.

Bonding Requirements

For any construction contracts or subcontracts exceeding **\$50,000.00**, the following is required:

1. A bid guarantee from each bidder equivalent to the bid price. The "bid guarantee" shall consist of a firm commitment such as a bid bond, certified check for 5 percent (5%) of total bid, or other negotiable instrument accompanying a bid as assurance that the bidder will, upon acceptance of his bid, execute such contractual documents as may be required within the time specified.
2. A payment and performance bond on the part of the contractor for 100 percent (100%) of the contract price.

A "payment bond" is one executed in connection with a contract to assure payment as required by law of all persons supplying labor and material in the execution of the work provided for in the contract.

A "performance bond" is one executed in connection with a contract to secure fulfillment of all the contractor's obligations under such contract.

Where bonds are required, the bonds shall be obtained from companies holding certificates of authority as acceptable sureties pursuant to 31 CFR part 223, "Surety Companies Doing Business with the United States."

OR

In lieu of acquiring the payment and performance bonds, Grantee will accept an irrevocable line of credit listing Grantee as the sole beneficiary and equal to (a) the greater of the contract award amount or (b) 25% of the total construction contract. The line of credit must be issued for the entire construction period plus one (1) year following construction completion

Demonstration of Capacity

All bidders are required to submit a statement(s) of experience, proposed plans for performing the work, and equipment available by completing the Demonstration of Capacity Form attached to this bid proposal.

Minority Owned Firms and Women's Business Enterprises

GCLBA is seeking to encourage participation by respondents who are small and minority-owned firms, women's business enterprises and labor surplus area firms.

HUD Debarred List and Excluded Parties List System

Names of owner(s) and the contractor firm awarded the winning bid on this proposal will be reviewed on the HUD Funding Disqualifications Limited Denial of Participation, HUD Funding Disqualifications and Voluntary Abstentions list https://www5.hud.gov/ecpcis/main/ECPCIS_List.jsp and the Excluded Parties List System <https://www.epls.gov/epls/search.do> . Mechanical, electrical and plumbing contractors will also be reviewed on Debarred List and Excluded Parties List System. The subcontractor information form is attached which must be submitted with the bid.

Lead Safe Work Practices

Lead safe work practices must be used for all rehabilitation activities and performed in accordance with applicable federal, state and local laws, ordinances, codes or regulations governing evaluation and hazard reduction.

Timeline for Completion

This project must be completed within 120 days from the date the GCLBA issues a notice to proceed. This includes all work items included in the bid and GCLBA final approval at time of completion and a certificate of occupancy issued by the City of Flint Department of Building and Safety.

2011 Certificate to do Business with Genesee County

Each contractor must submit one copy of their 2011 CERTIFICATE TO DO BUSINESS WITH GENESEE COUNTY. The Land Bank follows Genesee County Office of Equity and Diversity policies and procedures for this process. For further information on this requirement, contact the Genesee County Office of Equity and Diversity, 1101 Beach Street, Room 343, Flint, Michigan 48502, phone (810) 257-3028; fax (810) 768-7943.

Federal Compliance Requirements

The contractor must comply with all of the following federal guidelines for this rehabilitation project:

1. OSHA 29 CRF 1926- Construction Industry Standards
2. 29 CFR 1926.62- Construction Industry Lead Standards
3. 29 CFR 1910.1200 – Hazard Communication
4. 40 CFR Part 261- EPA Regulations
5. HUD Title X parts 1012-1013
6. Federal Labor Standards and Provisions
7. Equal Opportunity Clause
8. Section 3 Clause
9. HUD Contract and Subcontract Activity

Questions and Addendums

Questions regarding this bid should be directed to Kyle Stottmeister at (810) 257-3088 ext. 533 or email to kstottmeister@thelandbank.org. Addendums to this bid proposal may be found at the GCLBA website at www.thelandbank.org under the tab current bids. Please check the website for updates to this bid package.



CERTIFICATION FORM NOTE

THIS PAGE MUST BE COMPLETED AND INCLUDED WITH THE SUBMITTAL CERTIFICATION

The undersigned hereby certifies, on behalf of the Respondent named in this Certification (the "Respondent"), that the information provided in this bid submittal to GCLBA is accurate and complete, and I am duly authorized to submit same. I hereby certify that the Respondent has reviewed this bid proposal in its entirety and accepts its terms and conditions.

(Name of Respondent)

(Signature of Authorized Representative)

(Typed Name of Authorized Representative)

(Title)

(Date)



DEMONSTRATION OF CAPACITY

Company Name: _____

Statement of Experience

Years of Experience: _____

Proposed Plans for Performing the Work

Date contractor can begin work: _____

Date Contractor can complete work by: _____

Equipment Available

I certify that I have the necessary equipment available in order to complete the work outlined in this bid and accompanying specifications.

Signed this _____ day of _____, _____

Contractor Name (please print)

Contractor Signature



SUBCONTRACTOR INFORMATION FORM

Please provide the following information requested below on your mechanical, electrical and plumbing subcontractors for GCLBA to check the: 1) HUD Funding Disqualifications Limited Denial of Participation, HUD Funding Disqualifications and Voluntary Abstentions list and the 2) Excluded Parties List System. Is general contractor is self-performing these items please indicate it on this list.

Mechanical Subcontractor

Firm Name: _____

Owner(s) Name(s): _____

Address, City, State, Zip: _____

Phone number: _____

Electrical Subcontractor

Firm Name: _____

Owner(s) Name(s): _____

Address, City, State, Zip: _____

Phone number: _____

Plumbing Subcontractor

Firm Name: _____

Owner(s) Name(s): _____

Address, City, State, Zip: _____

Phone number: _____



CONTRACTOR BID FORM

Owner Name: Genesee County Land Bank Authority

Contact Person/ Spec Writer: Kyle Stottmeister

Contact Phone Number: (810) 257-3088 ext. 533

Contact Email: kstottmeister@thelandbank.org

Bid Submission Deadline Date: Monday, August 29, 2011 before 3:00 pm

Property Address: 2448 Thomas St., Flint, MI 48504

**Bid Offer as per
Attached Specifications \$** _____

Contractor Name: _____

Contractor Signature: _____ **Date:** _____

Contractor Address: _____

Contractor Phone: _____

Contractor Email: _____

Workers Comp Insurance Expires Date: _____ **Liability Insurance Expires Date:** _____

Note: Bid package includes one (1) set of specifications. One copy of the specifications must be completed and returned with this bid form that must be line priced in clearly legible numbers (ink or typewritten)



Section 3 Certification Process in the City of Flint

GCLBA follows the City of Flint's Section 3 Certification Process for the NSP 2 Program. If the contractor does not have Section 3 Certification at time of bid submission, the contractor must submit a letter stating compliance with Section 3 Certification will be achieved within 10 days of receiving contract award.

The City of Flint has strengthened the HUD requirements for Section 3. Section 3 Residents must live in the City of Flint to qualify for the GCLBA and City of Flint NSP 2 - Section 3 Program. The City of Flint has built a partnership with Mott Workforce Development to assist with certification of Section 3 Residents and Mott Workforce Development has a list of eligible Section 3 workers that the General Contractor can connect with for assistance in meeting Section 3 requirements. There is currently over 300 Section 3 Residents Certified through Mott Workforce Development with various skill sets in construction related fields.

Section 3 Business Certification

Please contact Tracy Atkinson from the City of Flint Department of Community and Economic Development (810) 766-7426 ext. 3059 or tatkinson@cityofflint.com for information regarding company Section 3 Certification.

Section 3 Residents Certification

Mott Community College Workforce Development can provide assistance with employee and laborer Section 3 Certifications. Please contact Dorian Jackson, Job Development Specialist (810) 232-2548 or dorian.jackson@mcc.edu or Kathleen Levallier, Job Development Specialist (810) 232-4674 or kathleen.levallier@mcc.edu for more information.

Attachments

The following documents are attached in order to help meet the Section 3 requirements:

- a. Section 3 Clause
- b. City of Flint – Section 3 Plan Addendum
- c. Certification for Business Concerns Seeking Section 3 Preference in Contracting and Demonstration of Capability
- d. Resident Employment Opportunity Data

SPECS BY LOCATION/TRADE

8/10/2011

Work Write-up/Re-Bid: _____
 Walk-Through Date: _____
 Bid Date: _____
 Initial: _____

Case Number: _____
 Construction Specialist: _____
 Phone: _____

Address: 2448 Thomas Street

Unit: Unit 01

Location: 1 - General Requirements

Approx. Wall SF: 1,184

Ceiling/Floor SF: 1,200

Spec #	Spec	Quantity	Units	Unit Price	Total Price
Trade: 1 General Requirements					
36	BUILDING PERMIT REQUIRED The contractor is responsible for submitting this owner-prepared work write up to the building department, applying for, paying for and receiving a building permit prior to starting any work.	1.00	EA	_____	_____
37	ELECTRICAL PERMIT REQUIRED Prior to the start of work, the contractor shall create any documentation necessary to apply for, pay for and receive an electrical permit on behalf of the owner.	1.00	EA	_____	_____
38	PLUMBING PERMIT REQUIRED Prior to the start of work, the contractor shall: create a riser diagram, septic layout and all other documentation needed to apply for, pay for and receive a plumbing permit on behalf of the owner.	1.00	EA	_____	_____
39	HVAC PERMIT REQUIRED Prior to the start of the heating/cooling work, the contractor shall create a heating distribution layout and perform heat/cooling loss calculations and all other documentation needed to apply for, pay for and receive an HVAC permit on behalf of the owner.	1.00	EA	_____	_____
93	BID AND PERFORMANCE BOND IN COMPLIANCE WITH REQUIREMENTS Prior to commencing work, contractor shall provide owner with a bond written on the AIA form for 100% of the contract, callable in the event of either non- performance or non-payment.	1.00	M	_____	_____

Trade: 9 Environmental Rehab

2070	ASBESTOS ABATEMENT Secure & isolate room, provide protective floor coverings when not removing floor tile. Pre-treat surface with wetting agent. Provide worker protection including whole body coveralls, respirators, & decontamination area. Dispose of asbestos in clearly identified disposal drums & HEPA vacuum entire area. All work must be done by a licensed Asbestos abatement company. Abate all hazards identified on asbestos report. <ol style="list-style-type: none"> 1. Duct wrap 2" tape - 40 linear ft. 2. Duct wrap insulation - 98 sq. ft. 3. All additional hazards identified (thermostat, refrigerator, light bulbs, paint, etc) 	1.00	AL	_____	_____
9007	CLEAN TO LEAD CLEARANCE Prior to final acceptance of the lead hazard reduction work and all rehabilitation work, the property shall be visually inspected for	1,200.00	SF	_____	_____

Location: 1 - General Requirements

Approx. Wall SF: 1,184

Ceiling/Floor SF: 1,200

Spec #	Spec	Quantity	Units	Unit Price	Total Price
--------	------	----------	-------	------------	-------------

Trade: 9 Environmental Rehab

window troughs. The contractor shall re-clean (Using the HEPA/wash/HEPA method) all applicable components and surfaces and pay for all additional clearance dust sampling if any dust sample results exceedd the thresholds of 40 ug/SF for floors, 250 ug/Sf for window sills and 400 ug/SF for window troughs.

Bidder: _____

Location Total: _____

Location: 2 - Interior

Approx. Wall SF: 1,184

Ceiling/Floor SF: 1,200

Spec #	Spec	Quantity	Units	Unit Price	Total Price
--------	------	----------	-------	------------	-------------

Trade: 10 Carpentry

2350	FLOOR--REFINISH WOOD Drum sand and edge floor. Counter sink all nails and fill holes. Vacuum and tack rag room. Apply a sanding sealer and two coats of oil based polyurethane varnish. Vacuum room.	900.00	SF	_____	_____
2980	WINDOW--VINYL SINGLE HNG DBL GLZ Field measure, order and install a vinyl, single hung, double glazed, one-over-one window and jamb including screen, caulk, interior casing and exterior trim. Include extension jamb if necessary. Windows should have integrated J-channel if used in conjunction with new vinyl siding. Windows must be Energy Star rated. Install half screen. See lead report.	10.00	EA	_____	_____
2981	Window - VINYL SLIDER, DOUBLE GLAZE Field measure, order and install a vinyl, slider, double glazed, window and jamb including screen, caulk, interior casing and exterior trim. Windows must be Energy Star rated. Window should have integrated J-channel if siding is being replaced as well. Install half screen.	1.00	EA	_____	_____
3185	DOOR--PREHUNG METAL ENTRANCE Dispose of door and frame. Install a prehung metal, insulated, 6-panel entrance door and jamb including interior and exterior casing, threshold, one entrance and one mortised deadbolt keyed alike (Schlage, brass finish or approved equivalent). Paint with two coats of exterior acrylic latex paint (Owner's choice of color). Front door should be decorative oval at least 1/2 light. See lead report.	3.00	EA	_____	_____
3187	DOOR--SLIDING GLASS UNIT Dispose of door and frame. Install a prehung vinyl, insulated,sliding door and jamb unit, including interior and exterior casing, weatherstripping, threshold, and locking hardware.	1.00	EA	_____	_____
3210	STORM DOOR--ALUMINUM Install an aluminum combination storm and screen door with	3.00	EA	_____	_____

Location: 2 - Interior

Approx. Wall SF: 1,184

Ceiling/Floor SF: 1,200

Spec #	Spec	Quantity	Units	Unit Price	Total Price
Trade: 10	Carpentry				
	in front of entrance door with decorative oval glass it should be full view glass not split screen.				
3355	DOOR--PREHUNG 6 PANEL INT, HOLLOW Install 6-panel, hollow core, masonite, prehung door. Include privacy lockset and 2 butt hinges. Include casing both sides Replace throughout house. See lead report.	9.00	EA	_____	_____
Trade: 16	Conservation				
4908	WALL INSULATION--DENSE PACK CELULOSE--GCI After sealing cavities drill 2 1/8" to 2 9/16" access holes for each stud cavity in the areas specified in interior or exterior locations. Install blow in borax treated (no ammonium sulfate permitted), cellulose insulation per manufacturer's specifications and dense-packed into all specified wall cavities to a minimum density of 3.5 Lbs. per Cubic Foot for the entire cavity. Use a 1" to 1 1/4" ID vinyl "wall tube" attached to the standard cellulose blower tubing to place the cellulose deep into the wall cavity. Check each stud cavity for blocking and other obstructions prior to blowing. Carefully seal all drilled holes with wood or foam plugs and patch all holes to match surrounding materials if the surface is exposed. In balloon framed houses insure that blown cellulose is blocked from entering floor cavities such as 2nd floor floors.	1,200.00	SF	_____	_____
Trade: 19	Paint & Wallpaper				
5566	PREP & PAINT HOUSE (INTERIOR) Remove/cover all hardware, fixtures not to be painted. Wet scrape loose, cracked, peeling, blistered surfaces. Feather edges & dull gloss surfaces with sandpaper. Clean all surfaces. Spot prime and top coat trim, ceiling, walls, doors & windows with owner's choice of premixed latex. Ceilings will be flat white, trim will be semi-gloss white, and walls will be owner's choice of color. Include any closets.	1,200.00	SF	_____	_____
Trade: 20	Floor Coverings				
5930	UNDERLAY & VINYL SHEET GOODS Install 1/4" underlayment (micro ply, birch plywood) , using 7d screw shank or cement coated nails, or narrow crown staples, 6" on center allowing a 1/4" gap at wall. Install 070" thick, backed vinyl sheet goods w/ minimum seams, per manufact. recommendations. Caulk edges of vinyl w/clear silicone caulk to create positive seal. Install metal edge strips in openings & shoe molding (Shoe molding along cabinets or vanities will match stain color on cabinets). \$15 material allowance for vinyl. Owner to pick style and color. Install in kitchen, bathroom, basement stair landing, front foyer, and solarium. See lead report.	200.00	SF	_____	_____

Location: 2 - Interior

Approx. Wall SF: 1,184

Ceiling/Floor SF: 1,200

Spec #	Spec	Quantity	Units	Unit Price	Total Price
Trade: 20	Floor Coverings				
5960	REMOVE FLOOR COVERING TO SUBFLOOR Remove floor covering to subfloor, remove all staples/nails, inspect subfloor for water/mold damage. Remove all transitions.	1,200.00	SF	_____	_____
5970	CARPET AND PAD Install FHA approved, nylon, plush carpet over a 1/2" medium density rebond pad w/ a minimum of seams. Stretch carpet to eliminate puckers, scallops & ripples. Include tackless strips, metal edge strips, and mending tape to cover entire floor including closets. On stairs, fasten carpet and pad at top and bottom of each riser. Carpet and pad material allowance \$15/sy. Owner's choice of in stockcolor and pattern. Install in back room	34.00	SY	_____	_____

Trade: 23 Electric

7560	RECEPTACLE REPLACE Replace receptacle with duplex receptacle and plastic cover plate. Match existing color. Replace all outlets throughout house	1.00	AL	_____	_____
7675	SWITCH REPLACE Replace light switch with single pole, toggle switch and cover plate. Match existing color. Replace all switches throughout house.	1.00	EA	_____	_____
7805	SMOKE DETECTOR--BATTERY POWERED Install a UL approved, ceiling mounted, battery powered smoke and fire detector and battery. Must have 5 year Lithium-ion battery. Install one in each bedroom, one in the hall outside the bedrooms, one in basement, and one on main floor (if two story).	5.00	EA	_____	_____

Trade: 1200 Furnishings (CSI)

C12500	INSTALL WINDOW TREATMENTS Install window treatments in all windows. Owner will pick treatments (\$35 material allowance for standard windows, \$75 for windows over 5' wide).	13.00	EA	_____	_____
---------------	---	-------	----	-------	-------

Bidder: _____

Location Total: _____

Location: 3 - Kitchen

Approx. Wall SF: 288

Ceiling/Floor SF: 80

Spec #	Spec	Quantity	Units	Unit Price	Total Price
Trade: 10	Carpentry				
3715	CABINET--WOOD BASE Replace base cabinets. Install base cabinet with doors of solid oak or maple. Cabinet will have solid oak or maple stiles, 1/2"	9.00	LF	_____	_____

Location: 3 - Kitchen

Approx. Wall SF: 288

Ceiling/Floor SF: 80

Spec #	Spec	Quantity	Units	Unit Price	Total Price
Trade: 10 Carpentry					
	material. Cabinets will have pulls or knobs and will match the finish on the faucet. Cabinets will be Kountry Wood Products Harmony Line - Bristol Maple (Or approved Equivalent) Available at Starline Kitchen and Bath				
3725	CABINET--WOOD WALL Replace wall cabinets. Field measure and screw to studs, level and plumb, kitchen wall cabinet. Door to be solid wood. Frame to have solid wood stiles, 1/2" particle board sides, metal or plastic corner bracing. Cabinets will have pulls or knobs and will match the finish on the faucet. Cabinets will be Kountry Wood Products Harmony Line - Bristol Maple (Or approved Equivalent) Available at Starline Kitchen and Bath	13.00	LF	_____	_____
3747	INSTALL POST FORM LAMINATED COUNTERTOP Dispose of existing counter top. Field measure for sizing. Provide end-caps and cutout for sink. Caulk countertop to adjoining walls with low VOC caulking to match wall color. Owner's choice of in-stock color and texture.	11.00	LF	_____	_____
Trade: 22 Plumbing					
6835	SINK--DOUBLE BOWL COMPLETE--GCI Install a 22 gauge 33" x 22" x 8" double bowl, stainless steel, self rimming kitchen sink including a Delta "Cicera" single handle faucet - model #468-SSSD-DST - brushed stainless finish (or approved equivalent), trap, supply lines, shut-off valves & escutcheon plates on all supply & drain lines. NOTE: All copper is to be soldered & all PVC fittings glued.	1.00	EA	_____	_____
Trade: 23 Electric					
7730	LIGHT FIXTURE--REPLACE Replace a ceiling mounted, UL approved, light fixture with shade and lamps. \$150 allowance for fixture. Owner will pick fixture. Bulbs should be CFL or approved high efficiency bulb.	1.00	EA	_____	_____
7845	GARBAGE DISPOSAL AND CIRCUIT Mount a 1/2 horsepower garbage disposal with a stainless steel chamber under sink and connect to waste line. Install an ivory toggle switch on wall adjacent sink and power wiring on independent 15 amp circuit. Fish wire and patch all tear out.	1.00	EA	_____	_____
7860	MICROWAVE RANGE HOOD - INSTALL Install a combination microwave/recirculating range hood over oven. Run on separate 20 amp circuit. Include new wiring and outlet, repair drywall as necessary. Microwave should be white, Maytag, Model # MMV5208WS (\$350 allowance) or approved equivalent.	1.00	EA	_____	_____

Address: 2448 Thomas Street

Unit: Unit 01

Location: 3 - Kitchen

Approx. Wall SF: 288

Ceiling/Floor SF: 80

Spec #	Spec	Quantity	Units	Unit Price	Total Price
--------	------	----------	-------	------------	-------------

Trade: 25 Appliances

8491	DISHWASHER--2 CYCLE--GCI Provide and install a 24" white, 2 cycle, built-in Energy Star® labeled dishwasher including all alterations and connections to plumbing and electric system. Whirlpool #: 267844 Model: DU811SWPU - or - GE Model GSD1300NWW or approved equivalent.	1.00	EA	_____	_____
------	--	------	----	-------	-------

Bidder: _____

Location Total: _____

Location: 4 - Dining Room

Approx. Wall SF: 336

Ceiling/Floor SF: 104

Spec #	Spec	Quantity	Units	Unit Price	Total Price
--------	------	----------	-------	------------	-------------

Trade: 23 Electric

7730	LIGHT FIXTURE--REPLACE Replace a ceiling mounted, UL approved, light fixture with shade and lamps. \$150 allowance for fixture. Owner will pick fixture. Bulbs should be CFL or approved high efficiency bulb.	1.00	EA	_____	_____
------	---	------	----	-------	-------

Bidder: _____

Location Total: _____

Location: 5 - Living Room

Approx. Wall SF: 490

Ceiling/Floor SF: 212

Spec #	Spec	Quantity	Units	Unit Price	Total Price
--------	------	----------	-------	------------	-------------

Trade: 7 Masonry

1410	FIREPLACE REPAIR--CUSTOM Clean and check fireplace. Repair damper if necessary to ensure proper operation.	1.00	EA	_____	_____
------	--	------	----	-------	-------

Trade: 10 Carpentry

3260	REWORK FRENCH DOOR Rehang door. Adjust door and lockset to operate properly. If door rubs carpeting, trim bottom of door to clear carpeting.	1.00	EA	_____	_____
------	--	------	----	-------	-------

Bidder: _____

Location Total: _____

Location: 6 - Solarium

Approx. Wall SF: 288

Ceiling/Floor SF: 65

Spec #	Spec	Quantity	Units	Unit Price	Total Price
--------	------	----------	-------	------------	-------------

Trade: 10 Carpentry

2415	CROWN MOULDING Replace existing crown moulding with same size and type. Match existing as closely as possible.	25.00	LF	_____	_____
3187	DOOR-15 LIGHT FRENCH Dispose of door and frame. Install a prehung vinyl or steel,	1.00	EA	_____	_____

Address: 2448 Thomas Street

Unit: Unit 01

Location: 6 - Solarium

Approx. Wall SF: 288

Ceiling/Floor SF: 65

Spec #	Spec	Quantity	Units	Unit Price	Total Price
--------	------	----------	-------	------------	-------------

Trade: 10 Carpentry

exterior casing, weatherstripping, threshold, and locking hardware (should match other doors).

See lead report.

Trade: 16 Conservation

4805 NEW STORM WINDOWS

6.00 EA _____

Install new storm windows on openings in solarium.

Trade: 23 Electric

7730 LIGHT FIXTURE--REPLACE

1.00 EA _____

Replace a wall mounted, UL approved, light fixture with shade and lamps. \$50 allowance for fixture. Owner will pick fixture. Bulbs should be CFL or approved high efficiency bulb.

Bidder: _____

Location Total: _____

Location: 7 - Back Room

Approx. Wall SF: 576

Ceiling/Floor SF: 288

Spec #	Spec	Quantity	Units	Unit Price	Total Price
--------	------	----------	-------	------------	-------------

Trade: 9 Environmental Rehab

9212 INSTALL CEILING TILES--FIBERGLASS, ENCAPSULATE SOFFIT

288.00 SF _____

Remove existing ceiling tiles in back room. Install a 5/8" vinyl faced fiberglass 2 x 4 drop-in tile in existing track.

Straighten track where necessary.

Wetscrape and encapsulate soffit and fascia prior to installing tiles

Trade: 16 Conservation

4805 CLEAN WINDOWS

6.00 EA _____

Clean existing windows with non abrasive cleanser and windex. Adjust locking mechanisms if necessary to ensure proper operation and security.

Trade: 23 Electric

7730 LIGHT FIXTURE--REPLACE

1.00 EA _____

Replace a wall mounted, UL approved, light fixture with shade and lamps. \$50 allowance for fixture. Owner will pick fixture. Bulbs should be CFL or approved high efficiency bulb.

Bidder: _____

Location Total: _____

Location: 8 - Strairway and Upstairs Hall

Approx. Wall SF: 368

Ceiling/Floor SF: 60

Location: 8 - Strairway and Upstairs Hall

Approx. Wall SF: 368

Ceiling/Floor SF: 60

Spec #	Spec	Quantity	Units	Unit Price	Total Price
Trade: 23	Electric				
7730	LIGHT FIXTURE--REPLACE Replace a ceiling mounted, UL approved, light fixture with shade and lamps. \$50 allowance for fixture. Owner will pick fixture. Bulbs should be CFL or approved high efficiency bulb.	1.00	EA	_____	_____
Bidder:	_____	Location Total: _____			

Location: 9 - Front bedroom

Approx. Wall SF: 352

Ceiling/Floor SF: 117

Spec #	Spec	Quantity	Units	Unit Price	Total Price
Trade: 10	Carpentry				
4010	CLOSET POLE Field measure and install 1-1/2" diameter wood closet pole and sockets.	1.00	EA	_____	_____
Trade: 23	Electric				
8017	ENERGY STAR CEILING FAN LIGHT FIXTURE--GCI Install an ENERGY STAR® approved 42- 52 inch white ceiling fan switched at the room entrance. Include fan mounting box if necessary. Bulbs should be CFL or approved high efficiency bulb.	1.00	EA	_____	_____
Bidder:	_____	Location Total: _____			

Location: 10 - N.W. Bedroom

Approx. Wall SF: 400

Ceiling/Floor SF: 156

Spec #	Spec	Quantity	Units	Unit Price	Total Price
Trade: 10	Carpentry				
2406	BASEBOARD--COLONIAL 3 1/4" Remove existing and install finger jointed (or MDF) 3-1/4" colonial base with finish nails of sufficient length to penetrate framing 1". Mitre all lap joints, and break all lap joints over framing.	50.00	LF	_____	_____
4010	CLOSET POLE Field measure and install 1-1/2" diameter wood closet pole and sockets.	1.00	EA	_____	_____
Trade: 17	Drywall & Plaster				
5235	LAMINATE 1/2" DRYWALL Hang 1/2" gypsum over wall or ceiling surface with screws 8" on center and a bead of construction adhesive 20" on center. Butt drywall to door and window casing and apply J channel molding. Remove top molding from 3-piece base and reinstall after surface is paint-ready. Tape, 3-coat finish and sand ready for paint.	550.00	SF	_____	_____

Address: 2448 Thomas Street

Unit: Unit 01

Location: 10 - N.W. Bedroom

Approx. Wall SF: 400

Ceiling/Floor SF: 156

Spec #	Spec	Quantity	Units	Unit Price	Total Price
--------	------	----------	-------	------------	-------------

Trade: 17 Drywall & Plaster

Laminate walls and ceiling. Include closet.
See lead report.

Trade: 23 Electric

8017	ENERGY STAR CEILING FAN LIGHT FIXTURE--GCI	1.00	EA	_____	_____
------	---	------	----	-------	-------

Install an ENERGY STAR® approved 42- 52 inch white ceiling fan switched at the room entrance. Include fan mounting box if necessary.
Bulbs should be CFL or approved high efficiency bulb.

Bidder: _____

Location Total: _____

Location: 11 - N.E. Bedroom

Approx. Wall SF: 336

Ceiling/Floor SF: 108

Spec #	Spec	Quantity	Units	Unit Price	Total Price
--------	------	----------	-------	------------	-------------

Trade: 10 Carpentry

4010	CLOSET POLE	1.00	EA	_____	_____
------	--------------------	------	----	-------	-------

Field measure and install 1-1/2" diameter wood closet pole and sockets.

Trade: 23 Electric

8017	ENERGY STAR CEILING FAN LIGHT FIXTURE--GCI	1.00	EA	_____	_____
------	---	------	----	-------	-------

Install an ENERGY STAR® approved 42- 52 inch white ceiling fan switched at the room entrance. Include fan mounting box if necessary.
Bulbs should be CFL or approved high efficiency bulb.

Bidder: _____

Location Total: _____

Location: 12 - Bathroom

Approx. Wall SF: 240

Ceiling/Floor SF: 56

Spec #	Spec	Quantity	Units	Unit Price	Total Price
--------	------	----------	-------	------------	-------------

Trade: 5 Demolition & Disposal

735	DEMOLISH BATHROOM	1.00	EA	_____	_____
-----	--------------------------	------	----	-------	-------

Remove all bath fixtures. Remove drywall on walls to studs.
Remove all nails and prepare for new drywall

Trade: 10 Carpentry

2406	BASEBOARD--COLONIAL 3 1/4"	25.00	LF	_____	_____
------	-----------------------------------	-------	----	-------	-------

Install finger jointed (or MDF) 3-1/4" colonial base with finish nails of sufficient length to penetrate framing 1". Mitre all lap joints, and break all lap joints over framing.

2795	NEW STORMS	2.00	EA	_____	_____
------	-------------------	------	----	-------	-------

Install new custom storm windows

Location: 12 - Bathroom

Approx. Wall SF: 240

Ceiling/Floor SF: 56

Spec #	Spec	Quantity	Units	Unit Price	Total Price
Trade: 10 Carpentry					
3820	TOWEL SET-- 3-PIECE CHROME Install a chrome plated steel bath set comprised of a soap dish, 24" towel bar and toilet paper holder.	1.00	EA	_____	_____
3832	BATH MIRROR Install beveled edge mirror sized at the width of vanity by 36" high.	1.00	SF	_____	_____
Trade: 17 Drywall & Plaster					
5280	DRYWALL--WATER RESISTANT Hang, tape and 3 coat finish 1/2" water resistant drywall. Apply a 3/8" bead of adhesive to framing member and screw or nail 8"on center. Wet sand ready for paint.	300.00	SF	_____	_____
Trade: 22 Plumbing					
6901	VANITY--30" COMPLETE Install a 30" vanity complete with plywood cabinet, cultured marble top, Delta, single handle brushed stainless steel finish (like model #B510LF-SS or approved equivalent), supply risers, shut-off valves and all required waste connectors to complete the installation.	1.00	EA	_____	_____
6958	BATHTUB/SHOWER--5' FIBERGLASS--Sterling Install a 5', 4 piece, Kohler Sterling™, 60" x 30" x 72" - Complete Unit - fiberglass tub and shower unit complete with pop up drain and overflow, PVC waste & trap, single lever shower diverter, shower rod and Delta Faucet "Monitor" Model 1343 tub/shower faucet - Model #BT14496 - SS (or approved equivalent).	1.00	EA	_____	_____
7010	COMMODO--REPLACE--1.6 GPF--GCI Install a 2 piece, close coupled, white, vitreous china, commode with a maximum water usage per flush of 1.6 Gallons. Include plastic or pressed wood white seat, supply pipe, shut-off valve, flap valve and wax seal. Toilet should be Mansfield Model 135 elongated bowl (or approved equivalent)	1.00	EA	_____	_____
Trade: 23 Electric					
7753	REPLACE WALL LIGHT FIXTURE Replace fixture with a wall mounted fixture. Ensure proper operation with existing switch. \$50 fixture allowance, Owner will pick fixture. Bulbs should be CFL or approved high efficiency bulb.	1.00	EA	_____	_____
7818	INSTALL BATH LIGHT, VENT Install a an Energy Star approved ceiling mounted Fan/Light fixture rated for a min 100 watts w/ an exterior ducted vent fan capable of min. 80 CFM operating at 2.5 Sone or less, vented w/ damper to exterior such as NuTone QTREN080FLT. Switch fan & light using a single switch. Install 4" metal duct and vent to the exterior ideally through a wall or gable end using a 4"	1.00	EA	_____	_____

Address: 2448 Thomas Street

Unit: Unit 01

Location: 12 - Bathroom

Approx. Wall SF: 240

Ceiling/Floor SF: 56

Spec #	Spec	Quantity	Units	Unit Price	Total Price
Trade: 23	Electric				

hooded vent with damper. All duct seams shall be sealed with duct mastic. Insulate the ductwork with vinyl or foil faced R 6 minimum duct insulation. Repair any damage to the ceiling installation and air seal fan/light assembly to the ceiling with low VOC caulk.

Bidder: _____

Location Total: _____

Location: 13 - Attic

Approx. Wall SF: 480

Ceiling/Floor SF: 576

Spec #	Spec	Quantity	Units	Unit Price	Total Price
Trade: 16	Conservation				

4935	ATTIC R-49 CELLULOSE--GCI	500.00	SF	_____	_____
	Install blown- in cellulose insulation per manufacturer's specifications to R49. Maintain ventilation routes from soffit and other vents with baffles. Build curb around attic access if necessary. Insulate attic access with batt insulation.				

Bidder: _____

Location Total: _____

Location: 14 - Basement

Approx. Wall SF: 672

Ceiling/Floor SF: 576

Spec #	Spec	Quantity	Units	Unit Price	Total Price
Trade: 5	Demolition & Disposal				

746	DEMO CHIMNEY	1.00	EA	_____	_____
	Remove surplus masonry chimney by hand. After securing site and removing all potentially damaged vehicles, chisel bricks at mortar line to disassemble the chimney. Remove to basement. Repair roof and floors by framing hole and installing the appropriate thickness of OSB . Replace shingles with matching style and color. Repair drywall as necessary				

Trade: 10 **Carpentry**

2520	HANDRAIL--REPLACE INTERIOR	12.00	LF	_____	_____
	Install 2" round hardwood handrail with braces screwed to studs and handrail. Paint with 2 coats of white semi-gloss interior latex paint, sanded between coats.				

Trade: 16 **Conservation**

4996	INSULATE RIM JOIST--FOAM--GCI	100.00	LF	_____	_____
	After cleaning the area thoroughly, apply expanding foam to the rim joist at the entire perimeter of the basement and/or crawl space exterior walls. Install to R 19 at a minimum. Use a foam product that meets International Residential Code (IRC), Section R314.5.11, and Underwriters Laboratories, Inc. (UL) classification Certificate R7813 such as Dow FROTH-PAK FS				

Location: 14 - Basement

Approx. Wall SF: 672

Ceiling/Floor SF: 576

Spec #	Spec	Quantity	Units	Unit Price	Total Price
Trade: 16	Conservation				
	Foam or Handi-Foam Two Component E-84 Class 1 Foam. Insulate from the subfloor for the first floor to the top of the foundation wall and seal all penetrations and the top of the foundation. Seal all openings within the area of the rim joist created by plumbing, gas lines, electrical boxes or any other penetrations.				
Trade: 17	Drywall & Plaster				
5270	DRYWALL--1/2" Hang, tape and 3 coat finish 1/2" drywall. Apply a 3/8 bead of adhesive to each framing member (if applying to studs) and screw or nail 8" on center. Run boards with long dimension horizontal. Wet sand ready for paint. Laminate over walls and ceiling in basement stairway. See lead report.	275.00	SF	_____	_____
Trade: 19	Paint & Wallpaper				
5755	PREP & PAINT CONCRETE FLOOR Sweep clean entire floor. Clean with TSP and rinse thoroughly. Roll out one coat of owner's choice of premixed latex floor paint per manufacturer's recommendations.	600.00	SF	_____	_____
5760	PREP & PAINT CONCRETE WALL Scrape loose, peeling, cracked, blistered paint from concrete surface. Wash dirt fungus, dust from surface. Spot prime and top coat with owner's choice of premixed acrylic latex based flat. Wetscrape and Encapsulate ledges, gas line, beams, and support poles prior to painting.	600.00	SF	_____	_____
5795	SPRAY WITH BLEACH SOLUTION Using a mixture of Bleach and water (12:1 mixture ratio). Spray walls or floor to remove stains. Use appropriate ventilation and respirators.	600.00	SF	_____	_____
Trade: 21	HVAC				
6041	FURNACE 95+ GAS - REPLACE Size furnace to the living unit considering any areas which may be added or subtracted from the plan. Remove existing furnace and dispose of all other materials in a code legal dump. FURNACE: install a 95+ gas fired forced air furnace with minimum AFUE rating of 95% on 2" patio block to existing duct work & gas line. New furnace to be vented with PVC piping per manufacturer's specifications. New furnace will have minimum limited warranties of: 20 years on heat exchangers; 5 years on parts. Include auto set back thermostat controls, vent pipe & new shut-off valve. Rework cold air return if necessary to ensure easy access, good fit & easy replacement of air filter. An exterior return air filter box shall be installed on one side, both sides, or bottom of new furnace. Seal all exposed duct joints as a part of this item with Duct Mastic. Remove all existing cloth duct tape prior to installing mastic.	1.00	EA	_____	_____

Location: 14 - Basement

Approx. Wall SF: 672

Ceiling/Floor SF: 576

Spec #	Spec	Quantity	Units	Unit Price	Total Price
Trade: 21 HVAC					
6145	DUCT CLEANING Subcontract a certified duct cleaning company to remove grates and use a truck mounted cleaning system to remove all dust and particles from HVAC system. Provide written certificate at time of check request.	1,200.00	SF	_____	_____
6180	A/C CENTRAL UNIT Submit manuf's cut sheet & cooling load calcs to owner min 15 working days prior to installation. Install central A/C system w/ min EER of 13 including condensing unit, A type coil, control & power wiring, insulated freon lines, plenums, ext pad & connections to create a product capable of 72 F interior when ext is 86 F at 95% humidity. Provide owner w/factory warranty, manual & 1-yr contractors warranty. Do not install condenser until house is sold and closing date is set.	1.00	EA	_____	_____
6415	DRYER VENT--GCI Install 4" rigid galvanized vent tubing from the specified dryer location to a 4" wall mounted dryer vent hood with a back-flow preventer and NO screening. Do not fasten with nails, screws or other fasteners that protrude into the interior of the exhaust duct. Seal all seams in the system with duct mastic or aluminum foil tape, not duct tape. Secure duct and hood to framing.	1.00	EA	_____	_____
Trade: 22 Plumbing					
6630	SUPPLY--PEX Install flexible pex piping with a minimum number of couplings to fixtures. Install mechanical connectors and shut off valves at all fixtures. Size pipe to 1990 CABO minimums per table 2406.5.	150.00	LF	_____	_____
6705	WASTE LINES--INSPECT, REPORT Test waste lines for leaks and proper venting. Identify defects and submit to the agency a priced list of recommended repairs to bring structure into compliance with the current plumbing code.	1.00	AL	_____	_____
7071	HWH - HIGH EFFICIENCY 40 GAL GAS POWER VENTED--GCI Install a 40 gallon, glass lined, high efficient, power vented, insulated to R-7, gas water heater with a 7 year warranty. Include pressure & temperature relief valve, discharge tube to within 6" of floor, condensate pump, owners manual & all duct work to power vent to exterior. Provide separate electrical circuit & new gas piping from shut-off valve to fixture. Dispose of old water heater in code legal dump. If the HWH is located in a basement with a floor drain the discharge tube shall be directed to the drain. If it is located on an upper floor or if there is no floor drain, install a catch pan drained to the exterior.	1.00	EA	_____	_____
7115	LAUNDRY TUB AND FAUCET - REPLACE Remove existing sink to code legal dump. Install single bowl,	1.00	EA	_____	_____

Location: 14 - Basement

Approx. Wall SF: 672

Ceiling/Floor SF: 576

Spec #	Spec	Quantity	Units	Unit Price	Total Price
Trade: 22 Plumbing					
2 handle chrome laundry faucet. Hook up waste line.					
7135	HOSE BIBB Install a bronze, freeze free hose bibb on outside of structure with inside shut-off valve and backflow preventer. Seal exterior penetration with silicone caulk.	2.00	EA	_____	_____
Trade: 23 Electric					
7465	ELECTRIC SERVICE--100 AMP Dispose of old electric service to code legal dump. Install a residential, 100 amp, single phase, 3 wire electric service. Include a main disconnect, 12 circuit panel board, meter socket, weather head, service cable, and ground rod and cable. Caulk exterior service penetration. Install to Michigan Electrical Code Requirements. Include Arc Fault breakers in bedrooms. Repair all cut wiring in basement. Install junction boxes where necessary.	1.00	EA	_____	_____
7615	WASHER CIRCUIT 110\20 AMP Install a flush or surface mounted duplex outlet for a washing machine on a separate 20 amp circuit using #12 copper Romex.	1.00	EA	_____	_____
7620	DRYER CIRCUIT--30 AMP Install 220 volt, 30 amp, surface mounted receptacle on an individual circuit.	1.00	EA	_____	_____
7680	INSTALL 5 BASEMENT LIGHTS AND SWITCH Remove old light fixtures. Install 5 keyless single bulb fixtures (\$5 allowance) spaced evenly in basement. Run wire to new switch located on the latch side of basement door Bulbs should be CFL or approved high efficiency bulb.	1.00	EA	_____	_____
7730	LIGHT FIXTURE--REPLACE Replace a ceiling mounted, UL approved, light fixture with shade and lamps. \$50 allowance for fixture. Owner will pick fixture. Bulbs should be CFL or approved high efficiency bulb. Replace light at top of stairs	1.00	EA	_____	_____
Trade: 25 Appliances					
8530	DEHUMIDIFIER Install a 110 volt, 50 pint dehumidifier in basement or other indicated area. Include hose to drain for continuous use. Supply owner with warranty and instructions.	1.00	EA	_____	_____
Bidder: _____	Location Total: _____				

Location: 15 - Garage

Approx. Wall SF: 648

Ceiling/Floor SF: 308

Spec #	Spec	Quantity	Units	Unit Price	Total Price
--------	------	----------	-------	------------	-------------

Location: 15 - Garage

Approx. Wall SF: 648

Ceiling/Floor SF: 308

Spec #	Spec	Quantity	Units	Unit Price	Total Price
Trade: 10 Carpentry					
2640	SIDING--VINYL Remove existing siding and replace with vinyl siding including all cornice, corner, door and window trim after replacing all deteriorated exterior building components. Wrap home with 1/4 inch fan fold insulation and apply owner's choice of siding color, exposure and texture with 50 year warranty. Make sure corner pieces continue up to meet soffit on gable ends. Fan fold insulation is not necessary on garages. Replace siding on garage. Extend rafter tails to make 12 soffit on eave ends of garage, include osb sheathing. Add 2 x 6 pine on rake ends of gable to help flash siding.	7.00	SQ	_____	_____
3185	DOOR--PREHUNG METAL ENTRANCE Dispose of door and frame. Install a prehung metal, insulated, 6-panel entrance door and jamb including interior and exterior casing, threshold, one entrance and one mortised deadbolt keyed alike (Schlage, brass finish or approved equivalent). Paint with two coats of exterior acrylic latex paint (Owner's choice of color). Front door should be decorative oval at least 1/2 light.	1.00	EA	_____	_____
3200	DOOR OVERHEAD GARAGE Dispose of door, track and hardware. Install an insulated steel, 16'x 7' garage door including hardware, exterior trim and drip cap.	1.00	EA	_____	_____
Trade: 15 Roofing					
4760	SOFFIT & FASCIA Remove existing and install aluminum vented soffit and aluminum fascia. Cut channel in existing soffit if necessary to insure proper ventilation Cover 2 x 6 on rake ends with aluminum prior to siding.	44.00	LF	_____	_____
Trade: 23 Electric					
7515	35 AMP SUB PANEL Install a 4-circuit, electric sub-distribution panel. Include underground line in exterior conduit from house to garage.	1.00	EA	_____	_____
7575	20 AMP CIRCUIT--RECEPTACLE Install 20 amp, duplex receptacle with a matching plastic cover plate on a separate circuit with an individual over protection device. Fish wire and repair all tear out.	1.00	EA	_____	_____
7730	LIGHT FIXTURE--REPLACE Replace a ceiling mounted, UL approved, keyless fixture with bulb. \$15 allowance for fixture. Owner will pick fixture. Include 14/2 romex with one switch by entry door. Bulbs should be CFL or approved high efficiency bulb.	2.00	EA	_____	_____
7795	REPLACE GARAGE DOOR OPENER Replace existing garage door opener with screw type opener. (2 remotes)	1.00	EA	_____	_____

Bidder: _____

Location Total: _____

Location: 16 - Exterior

Approx. Wall SF: 0

Ceiling/Floor SF: 0

Spec #	Spec	Quantity	Units	Unit Price	Total Price
Trade: 4 Site Work					
475	LANDSCAPING ALLOWANCE Clear cut back yard. Remove any trees from within 15' of house, including stumps. Remove all trees from back yard. Bring in screened topsoil and raise grade in back yard by 4" plant grass seed and cover with straw. Trim shrubs in front yard.	1.00	AL	_____	_____
Trade: 6 Concrete & Paving					
955	DRIVEWAY--REPAVE ASPHALT Clean, spray tack coat and repave a 2" top coat of bituminous concrete over driveway surface. Contractor is to remove all existing asphalt from main sidewalk, then call for an inspection by the Bureau of Engineering Services to see if the City will repair existing sidewalk or replace it. No asphalt is to be placed on main sidewalks. Repave asphalt from street to garage entrance.	1,000.00	SF	_____	_____
Trade: 10 Carpentry					
2565	POWER WASH SIDING Remove stains and dirt from siding using high pressure water and detergent mix. Adjust pressure to eliminate damage to siding	1,200.00	SF	_____	_____
3575	TREATED WOOD PORCH Build a treated lumber porch/landing. Include piers, posts, stringers, and steps. Use appropriately sized floor joists for span. All foundation lumber should be approved for ground contact. Remove front porch cap and replace with 6 x 11 front porch.	66.00	EA	_____	_____
3875	HOUSE NUMBER SET Install 3" high metal or PVC house numbers on a 1"x 4" pine backer board painted with 2 coats of exterior white latex paint.	1.00	EA	_____	_____
3885	MAILBOX Dispose of mailbox and install a steel, black enamel finish, letter-size mail box with magazine rack and lock-eye for padlock.	1.00	EA	_____	_____
Trade: 15 Roofing					
4580	TEAR OFF AND REROOF SHINGLES Remove and dispose of all roofing & defective sheathing. Cut a 1" wide vent at ridge board. Replace up to 5 sf of sheathing per 100 sf of roof using pine board or CDX plywood of matching thickness. Staple 15 lb felt. Install preformed aluminum, drip edge, and vent pipe boots. Install a 220 lb fiberglass asphalt, dimensional shingle with a 30 yr warranty. Replace all flashing. Install shingle-over ridge vent. Include "Ice and water shield" where specified by code.	15.00	SQ	_____	_____

Address: 2448 Thomas Street

Unit: Unit 01

Location: 16 - Exterior

Approx. Wall SF: 0

Ceiling/Floor SF: 0

Spec #	Spec	Quantity	Units	Unit Price	Total Price
--------	------	----------	-------	------------	-------------

Trade: 15 Roofing

Call for "open roof" inspection prior to drying in. Include permit fee if no building permit is required.

Rework flashing by 2 upstairs front windows to make decent slope, cover with aluminum.

Include garage roof.

4635	GUTTER--5" SEAMLESS ALUMINUM	100.00	LF	_____	_____
------	-------------------------------------	--------	----	-------	-------

Dispose of gutter. Install 5", K- type, seamless, .027 gauge aluminum gutter to service roof. White or brown color choice by owner. Downspouts will have 4' removeable extensions.

Do not include garage.

Trade: 23 Electric

8045	DOORBELL SYSTEM	1.00	EA	_____	_____
------	------------------------	------	----	-------	-------

Install a wireless doorbell system containing a buzzer and two door buttons.

8165	ENTRANCE LIGHT FIXTURE--REPLACE	2.00	EA	_____	_____
------	--	------	----	-------	-------

Remove damaged light fixture and replace with an exterior, waterproof, single bulb fixture. \$50 fixture allowance.

Bidder: _____

Location Total: _____

Unit Total for 2448 Thomas Street, Unit Unit 01: _____

Address Grand Total for 2448 Thomas Street: _____



**COMBINATION LEAD BASED PAINT
INSPECTION AND
RISK ASSESSMENT SURVEY**

FOR THE PROPERTY KNOWN AS:

2448 Thomas
Flint, MI 48504

Owner's name: Genesee County Land Bank

Owner's Phone #: (810) 257-3088

Current Occupant's name: Vacant Residence

Date of Construction: 1940's



PREPARED FOR:

Genesee County Land Bank
452 S. Saginaw Street, 2nd floor
Flint, MI 48504
(810) 257-3088

LABWORK PROVIDED BY

Accurate Analytical Testing (AAT)
(734) 699-5227
NLLAP # 100986

DATE(S) OF ASSESSMENT:

August 1, 2011

REPORT PREPARED AND SUBMITTED BY:

Michael Gravlin
EPA Certified Lead Risk Assessor
Certification #: P-00313

ETC Job#: 137854

38900 West Huron River Drive, Romulus, MI 48174

PHONE: (734) 955-6600 FAX: (734) 955-6604

WEBSITE: www.2etc.com

TABLE OF CONTENTS

I. EXECUTIVE SUMMARY

Chart detailing lead hazards found at the home, severity of the hazard, priority and potential solutions (hazard control options) for each hazard.

II. PURPOSE AND SCOPE OF WORK

- A. Lead Inspections
- B. Lead Risk Assessments
- C. Project Limitations and Problems

III. REGULATORY INFORMATION

- A. Title X
- B. Department of Housing and Urban Development (HUD) Requirements
- C. Environmental Protection Agency (EPA):
- D. Occupational Safety and Health Administration (OSHA):
- E. City of Detroit (Ordinances and Codes)

IV. SAMPLE RESULTS AND INFORMATION

- A. Lead Paint Sampling
- B. Lead Dust Sampling
- C. Lead Soil Sampling

V. HAZARD CONTROL OPTION RECOMMENDATIONS

VI. RE-EVALUATION RECOMMENDATIONS

VII. COST ESTIMATES

VIII. RECOMMENDATIONS FOR FUTURE OPERATIONS AND MAINTENANCE

APPENDICES

- Appendix A - All Paint Sample Results (XRF Method)
- Appendix B - **Lead Paint Only** Sample Results (XRF Method)
- Appendix C - Potential Hazards
- Appendix D - Maps of Residence
- Appendix E - Resident Questionnaire and Building Condition Form
- Appendix F - Re-Evaluation Schedule Chart
- Appendix G—Site Photos

ETC - Environmental Services WILCO Environmental

<p align="center">Summary of Existing Lead Based Paint Hazards including Abatement and Interim Control Options</p>				
<i>Client</i>	Genesee County Land Bank			
<i>Survey Location:</i>	2448 Thomas St., Flint, MI 48504			
<i>Survey Date:</i>	08/01/11	Job#:	137854	
<i>Inspectors:</i>	Michael Gravlin			
<p align="center">The items listed here represent the lead based paint hazards found at this building/site. For each identified hazard, there are corresponding options for performing abatement (long term) fixes and interim control (shorter term) fixes. The client and/or their representative need to select the appropriate and affordable solution to address each of the identified hazards.</p> <p align="center">*Always refer to the Potential Hazard Chart (Appendix C) to determine where other lead painted items may be located as not to create additional hazards during the course of the work. If these items are disturbed, lead safe work practices must be followed.</p> <p align="center">*Selected abatement and interim control activities should be completed by a certified abatement contractor or when appropriate a certified renovation firm. After completing these activities, complete and thorough cleaning must be performed following EPA/HUD "Lead Safe Work Practices Procedures". Additionally, after all work has been completed, a final lead clearance should be conducted and may be required. It is the responsibility of the person(s) performing the lead hazard control work to ensure that all appropriate procedures and regulations are followed.</p>				
Identified Hazard	Severity	Priority	Abatement Options	Interim Control Options
Hazards throughout Home				
Dust levels in some window troughs / wells within the home were found to have elevated lead levels. Therefore, all window troughs should be considered to be lead contaminated.	High	High	The risk assessor believes that these high lead levels were caused by other lead hazards dealt with below or past renovation work. Therefore, after having completed all other abatement / interim control options, clean the entire house for lead dust thoroughly using the accepted HEPA-Wash-HEPA cleaning methods.	The risk assessor believes that these high lead levels were caused by other lead hazards dealt with below or past renovation work. Therefore, after having completed all other abatement / interim control options, clean the entire house for lead dust thoroughly using the accepted HEPA-Wash-HEPA cleaning methods.
Dust levels in some window sills / stools within the home were found to have elevated lead levels. Therefore, all window sills should be considered to be lead contaminated.	High	High	The risk assessor believes that these high lead levels were caused by other lead hazards dealt with below or past renovation work. Therefore, after having completed all other abatement / interim control options, clean the entire house for lead dust thoroughly using the accepted HEPA-Wash-HEPA cleaning methods.	The risk assessor believes that these high lead levels were caused by other lead hazards dealt with below or past renovation work. Therefore, after having completed all other abatement / interim control options, clean the entire house for lead dust thoroughly using the accepted HEPA-Wash-HEPA cleaning methods.
Dust levels on some floors within the home were found to have elevated lead levels. Therefore, all floors should be considered to be lead contaminated.	High	High	The risk assessor believes that these high lead levels were caused by other lead hazards dealt with below or past renovation work. Therefore, after having completed all other abatement / interim control options, clean the entire house for lead dust thoroughly using the accepted HEPA-Wash-HEPA cleaning methods.	The risk assessor believes that these high lead levels were caused by other lead hazards dealt with below or past renovation work. Therefore, after having completed all other abatement / interim control options, clean the entire house for lead dust thoroughly using the accepted HEPA-Wash-HEPA cleaning methods.
A majority of original wood window components (window sash exteriors, troughs and jambs) throughout the home were found to present lead hazards, rather than listing each on a room by room basis, all deteriorated window components should be considered lead hazards.	High	High	1) Remove and replace with new replacement windows or 2) replace individual lead painted components 3) enclose all lead painted surfaces or 4) strip all surfaces bare to the substrate, make necessary repairs, stabilize surfaces, and repaint. This applies only to older windows not the recently replaced windows within the home.	1) Use friction reduction treatments (jamb liners, weatherstripping, rubber padding, covers, etc.) to reduce wear or 2) Wet plane all friction / impact surfaces, wet scrape all remaining surfaces, make necessary repairs, stabilize all surfaces and repaint.

ETC - Environmental Services WILCO Environmental

<p align="center">Summary of Existing Lead Based Paint Hazards including Abatement and Interim Control Options</p>				
<i>Client</i>	Genesee County Land Bank			
<i>Survey Location:</i>	2448 Thomas St., Flint, MI 48504			
<i>Survey Date:</i>	08/01/11	Job#:	137854	
<i>Inspectors:</i>	Michael Gravlin			
<p align="center">The items listed here represent the lead based paint hazards found at this building/site. For each identified hazard, there are corresponding options for performing abatement (long term) fixes and interim control (shorter term) fixes. The client and/or their representative need to select the appropriate and affordable solution to address each of the identified hazards.</p> <p align="center">*Always refer to the Potential Hazard Chart (Appendix C) to determine where other lead painted items may be located as not to create additional hazards during the course of the work. If these items are disturbed, lead safe work practices must be followed.</p> <p align="center">*Selected abatement and interim control activities should be completed by a certified abatement contractor or when appropriate a certified renovation firm. After completing these activities, complete and thorough cleaning must be performed following EPA/HUD "Lead Safe Work Practices Procedures". Additionally, after all work has been completed, a final lead clearance should be conducted and may be required. It is the responsibility of the person(s) performing the lead hazard control work to ensure that all appropriate procedures and regulations are followed.</p>				
Identified Hazard	Severity	Priority	Abatement Options	Interim Control Options
Sun Room 2				
Door, jamb and threshold represent deteriorated lead paint friction/impact surface hazards	Low	High	1) Remove and replace with new door systems or 2) replace individual lead painted components or 3) strip all surfaces bare to the substrate, stabilize surfaces, and repaint.	1) Refit door to eliminate friction points, wet scrape/sand all surfaces, make necessary repairs, including installation of weatherstripping or other "soft" stop material, stabilize all surfaces and repaint 2) Use friction reduction treatments (jamb liners, weatherstripping, rubber padding, tread covers, etc.) to reduce wear or 3) Wet plane all friction / impact surfaces, wet scrape all remaining surfaces, make necessary repairs, stabilize all surfaces and repaint.
Floor represents a deteriorated lead paint friction/impact surface hazard	Medium	High	1) Enclose with Luann or other suitable flooring material or 2) Remove and replace flooring material or 3) strip all surfaces bare to the substrate, make necessary repairs and recoat. Note: Floors should be abated last.	Wet scrape / sand all surfaces, make necessary repairs, stabilize all surfaces, paint and cover with new floor covering (tread covers, carpet, vinyl tile, etc...) material.
Window sills/troughs and jambs represent deteriorated lead paint surface hazards	Medium	High	1) Wet scrape/sand all surfaces, make necessary repairs, stabilize surfaces and encapsulate with a Michigan approved encapsulant or 2) enclose by wrapping with vinyl or aluminum and seal or 3) remove and replace with new components or 4) strip all surfaces bare to the substrate (either chemically or using mechanical wet methods), make necessary repairs and recoat.	1) Wet scrape / sand all surfaces, make necessary repairs, stabilize all surfaces and repaint or 2) stabilize all surfaces and wrap with aluminum or vinyl
Crown Moldings represent deteriorated lead paint surface hazards	Low	Low	1) Remove and replace with new components or 2) wet scrape/sand all surfaces, make necessary repairs, stabilize surfaces and encapsulate with a Michigan approved encapsulant or 3) strip all surfaces bare to the substrate (either chemically or using mechanical wet methods), make necessary repairs and recoat.	Wet scrape / sand all surfaces, make necessary repairs, stabilize all surfaces and repaint.

ETC - Environmental Services WILCO Environmental

<p align="center">Summary of Existing Lead Based Paint Hazards including Abatement and Interim Control Options</p>				
<i>Client</i>	Genesee County Land Bank			
<i>Survey Location:</i>	2448 Thomas St., Flint, MI 48504			
<i>Survey Date:</i>	08/01/11	Job#:	137854	
<i>Inspectors:</i>	Michael Gravlin			
<p align="center">The items listed here represent the lead based paint hazards found at this building/site. For each identified hazard, there are corresponding options for performing abatement (long term) fixes and interim control (shorter term) fixes. The client and/or their representative need to select the appropriate and affordable solution to address each of the identified hazards.</p> <p align="center">*Always refer to the Potential Hazard Chart (Appendix C) to determine where other lead painted items may be located as not to create additional hazards during the course of the work. If these items are disturbed, lead safe work practices must be followed.</p> <p align="center">*Selected abatement and interim control activities should be completed by a certified abatement contractor or when appropriate a certified renovation firm. After completing these activities, complete and thorough cleaning must be performed following EPA/HUD "Lead Safe Work Practices Procedures". Additionally, after all work has been completed, a final lead clearance should be conducted and may be required. It is the responsibility of the person(s) performing the lead hazard control work to ensure that all appropriate procedures and regulations are followed.</p>				
Identified Hazard	Severity	Priority	Abatement Options	Interim Control Options
Mud Room 5				
Soffits (these are the original exterior soffits and would normally be covered by the drop ceiling tiles-this area is currently exposed) represent deteriorated lead paint surface hazards	Medium	Low	1) Wet scrape/sand all surfaces, make necessary repairs, stabilize surfaces and encapsulate with a Michigan approved encapsulant or 2) enclose by wrapping with vinyl or aluminum and seal or 3) remove and replace with new components or 4) strip all surfaces bare to the substrate (either chemically or using mechanical wet methods), make necessary repairs and recoat.	1) Wet scrape / sand all surfaces, make necessary repairs, stabilize all surfaces and repaint or 2) stabilize all surfaces and replace ceiling tile or cover with a suitable wallboard material
Kitchen 6				
Window sash interiors represent deteriorated lead paint friction/impact surface hazards	Medium	Medium	1) Remove and replace with new replacement windows or 2) replace individual lead painted components 3) enclose all lead painted surfaces or 4) strip all surfaces bare to the substrate, make necessary repairs, stabilize surfaces, and repaint.	1) Use friction reduction treatments (jamb liners, weatherstripping, rubber padding, tread covers, etc.) to reduce wear or 2) Wet plane all friction / impact surfaces, wet scrape all remaining surfaces, make necessary repairs, stabilize all surfaces and repaint.
Basement Stair 7				
Entry door jamb represents a deteriorated lead paint friction/impact surface hazard	Medium	Low	1) Remove and replace with new door systems or 2) replace individual lead painted components or 3) strip all surfaces bare to the substrate, stabilize surfaces, and repaint.	1) Refit door to eliminate friction points, wet scrape/sand all surfaces, make necessary repairs, including installation of weatherstripping or other "soft" stop material, stabilize all surfaces and repaint 2) Use friction reduction treatments (jamb liners, weatherstripping, rubber padding, tread covers, etc.) to reduce wear or 3) Wet plane all friction / impact surfaces, wet scrape all remaining surfaces, make necessary repairs, stabilize all surfaces and repaint.

ETC - Environmental Services WILCO Environmental

Summary of Existing Lead Based Paint Hazards including Abatement and Interim Control Options				
<i>Client</i>	Genesee County Land Bank			
<i>Survey Location:</i>	2448 Thomas St., Flint, MI 48504			
<i>Survey Date:</i>	08/01/11	Job#:	137854	
<i>Inspectors:</i>	Michael Gravlin			
<p align="center">The items listed here represent the lead based paint hazards found at this building/site. For each identified hazard, there are corresponding options for performing abatement (long term) fixes and interim control (shorter term) fixes. The client and/or their representative need to select the appropriate and affordable solution to address each of the identified hazards.</p> <p align="center">*Always refer to the Potential Hazard Chart (Appendix C) to determine where other lead painted items may be located as not to create additional hazards during the course of the work. If these items are disturbed, lead safe work practices must be followed.</p> <p align="center">*Selected abatement and interim control activities should be completed by a certified abatement contractor or when appropriate a certified renovation firm. After completing these activities, complete and thorough cleaning must be performed following EPA/HUD "Lead Safe Work Practices Procedures". Additionally, after all work has been completed, a final lead clearance should be conducted and may be required. It is the responsibility of the person(s) performing the lead hazard control work to ensure that all appropriate procedures and regulations are followed.</p>				
Identified Hazard	Severity	Priority	Abatement Options	Interim Control Options
Lower wall and ceiling represents deteriorated lead paint surface hazards	Low	Low	1) Enclose with drywall or other suitable wallboard material or 2) wet scrape/sand all surfaces, make necessary repairs, stabilize surfaces and encapsulate with a Michigan approved encapsulant.	1) Wet scrape / sand all surfaces, make necessary repairs, stabilize all surfaces and repaint or 2) stabilize all surfaces and cover with a suitable wallboard material
Ledges represent deteriorated lead paint surface hazard(s)	Low	Low	1) Remove and replace with new components or 2) wet scrape/sand all surfaces, make necessary repairs, stabilize surfaces and encapsulate with a Michigan approved encapsulant or 3) strip all surfaces bare to the substrate (either chemically or using mechanical wet methods), make necessary repairs and recoat.	Wet scrape / sand all surfaces, make necessary repairs, stabilize all surfaces and repaint.
Basement 8				
Beams and support poles represent deteriorated lead paint surface hazards	Medium	Low	1) Stabilize surfaces frame and and build a sealed enclosure around components or 2) remove and replace with new components or 3) wet scrape/sand all surfaces, make necessary repairs, stabilize surfaces and encapsulate with a Michigan approved encapsulant or 4) strip all surfaces bare to the substrate (either chemically or using mechanical wet methods), make necessary repairs and recoat.	1) Wet scrape / sand all surfaces, make necessary repairs, stabilize all surfaces and repaint or 2) stabilize all surfaces, frame and cover with a suitable wallboard material

ETC - Environmental Services WILCO Environmental

Summary of Existing Lead Based Paint Hazards including Abatement and Interim Control Options				
<i>Client</i>	Genesee County Land Bank			
<i>Survey Location:</i>	2448 Thomas St., Flint, MI 48504			
<i>Survey Date:</i>	08/01/11	Job#:	137854	
<i>Inspectors:</i>	Michael Gravlin			
<p>The items listed here represent the lead based paint hazards found at this building/site. For each identified hazard, there are corresponding options for performing abatement (long term) fixes and interim control (shorter term) fixes. The client and/or their representative need to select the appropriate and affordable solution to address each of the identified hazards.</p> <p>*Always refer to the Potential Hazard Chart (Appendix C) to determine where other lead painted items may be located as not to create additional hazards during the course of the work. If these items are disturbed, lead safe work practices must be followed.</p> <p>*Selected abatement and interim control activities should be completed by a certified abatement contractor or when appropriate a certified renovation firm. After completing these activities, complete and thorough cleaning must be performed following EPA/HUD "Lead Safe Work Practices Procedures". Additionally, after all work has been completed, a final lead clearance should be conducted and may be required. It is the responsibility of the person(s) performing the lead hazard control work to ensure that all appropriate procedures and regulations are followed.</p>				
Identified Hazard	Severity	Priority	Abatement Options	Interim Control Options
Gasline piping represents deteriorated lead paint surface hazards	Low	Low	1) Remove and replace with new components or 2) wet scrape/sand all surfaces, make necessary repairs, stabilize surfaces and encapsulate with a Michigan approved encapsulant or 3) strip all surfaces bare to the substrate (either chemically or using mechanical wet methods), make necessary repairs and recoat.	Wet scrape / sand all surfaces, make necessary repairs, stabilize all surfaces and repaint.
Hallway 10				
Door and closet casings represent deteriorated lead paint surface hazards	High	Low	1) Remove and replace with new components or 2) wet scrape/sand all surfaces, make necessary repairs, stabilize surfaces and encapsulate with a Michigan approved encapsulant or 3) strip all surfaces bare to the substrate (either chemically or using mechanical wet methods), make necessary repairs and recoat.	Wet scrape / sand all surfaces, make necessary repairs, stabilize all surfaces and repaint.
Non-friction side of door jambs represent deteriorated lead paint surface hazards	High	Low	1) Remove and replace with new components or 2) wet scrape/sand all surfaces, make necessary repairs, stabilize surfaces and encapsulate with a Michigan approved encapsulant or 3) strip all surfaces bare to the substrate (either chemically or using mechanical wet methods), make necessary repairs and recoat.	Wet scrape / sand all surfaces, make necessary repairs, stabilize all surfaces and repaint.

ETC - Environmental Services WILCO Environmental

<p align="center">Summary of Existing Lead Based Paint Hazards including Abatement and Interim Control Options</p>				
<i>Client</i>	Genesee County Land Bank			
<i>Survey Location:</i>	2448 Thomas St., Flint, MI 48504			
<i>Survey Date:</i>	08/01/11	Job#:	137854	
<i>Inspectors:</i>	Michael Gravlin			
<p align="center">The items listed here represent the lead based paint hazards found at this building/site. For each identified hazard, there are corresponding options for performing abatement (long term) fixes and interim control (shorter term) fixes. The client and/or their representative need to select the appropriate and affordable solution to address each of the identified hazards.</p> <p align="center">*Always refer to the Potential Hazard Chart (Appendix C) to determine where other lead painted items may be located as not to create additional hazards during the course of the work. If these items are disturbed, lead safe work practices must be followed.</p> <p align="center">*Selected abatement and interim control activities should be completed by a certified abatement contractor or when appropriate a certified renovation firm. After completing these activities, complete and thorough cleaning must be performed following EPA/HUD "Lead Safe Work Practices Procedures". Additionally, after all work has been completed, a final lead clearance should be conducted and may be required. It is the responsibility of the person(s) performing the lead hazard control work to ensure that all appropriate procedures and regulations are followed.</p>				
Identified Hazard	Severity	Priority	Abatement Options	Interim Control Options
Closet jamb represents a deteriorated lead paint friction/impact surface hazard	Medium	Low	1) Remove and replace with new door systems or 2) replace individual lead painted components or 3) strip all surfaces bare to the substrate, stabilize surfaces, and repaint.	1) Refit door to eliminate friction points, wet scrape/sand all surfaces, make necessary repairs, including installation of weatherstripping or other "soft" stop material, stabilize all surfaces and repaint 2) Use friction reduction treatments (jamb liners, weatherstripping, rubber padding, tread covers, etc.) to reduce wear or 3) Wet plane all friction / impact surfaces, wet scrape all remaining surfaces, make necessary repairs, stabilize all surfaces and repaint.
Bath 11				
Door, jamb and stops represent deteriorated lead paint friction/impact surface hazards	Medium	Low	1) Remove and replace with new door systems or 2) replace individual lead painted components or 3) strip all surfaces bare to the substrate, stabilize surfaces, and repaint.	1) Refit door to eliminate friction points, wet scrape/sand all surfaces, make necessary repairs, including installation of weatherstripping or other "soft" stop material, stabilize all surfaces and repaint 2) Use friction reduction treatments (jamb liners, weatherstripping, rubber padding, tread covers, etc.) to reduce wear or 3) Wet plane all friction / impact surfaces, wet scrape all remaining surfaces, make necessary repairs, stabilize all surfaces and repaint.
Bedroom 12				
Door, jamb and stops represent deteriorated lead paint friction/impact surface hazards	Medium	Low	1) Remove and replace with new door systems or 2) replace individual lead painted components or 3) strip all surfaces bare to the substrate, stabilize surfaces, and repaint.	1) Refit door to eliminate friction points, wet scrape/sand all surfaces, make necessary repairs, including installation of weatherstripping or other "soft" stop material, stabilize all surfaces and repaint 2) Use friction reduction treatments (jamb liners, weatherstripping, rubber padding, tread covers, etc.) to reduce wear or 3) Wet plane all friction / impact surfaces, wet scrape all remaining surfaces, make necessary repairs, stabilize all surfaces and repaint.
Closet door, jamb and stops represent deteriorated lead paint friction/impact surface hazards	Medium	Low	1) Remove and replace with new door systems or 2) replace individual lead painted components or 3) strip all surfaces bare to the substrate, stabilize surfaces, and repaint.	1) Refit door to eliminate friction points, wet scrape/sand all surfaces, make necessary repairs, including installation of weatherstripping or other "soft" stop material, stabilize all surfaces and repaint 2) Use friction reduction treatments (jamb liners, weatherstripping, rubber padding, tread covers, etc.) to reduce wear or 3) Wet plane all friction / impact surfaces, wet scrape all remaining surfaces, make necessary repairs, stabilize all surfaces and repaint.

ETC - Environmental Services WILCO Environmental

<p align="center">Summary of Existing Lead Based Paint Hazards including Abatement and Interim Control Options</p>				
<i>Client</i>	Genesee County Land Bank			
<i>Survey Location:</i>	2448 Thomas St., Flint, MI 48504			
<i>Survey Date:</i>	08/01/11	Job#:	137854	
<i>Inspectors:</i>	Michael Gravlin			
<p align="center">The items listed here represent the lead based paint hazards found at this building/site. For each identified hazard, there are corresponding options for performing abatement (long term) fixes and interim control (shorter term) fixes. The client and/or their representative need to select the appropriate and affordable solution to address each of the identified hazards.</p> <p align="center">*Always refer to the Potential Hazard Chart (Appendix C) to determine where other lead painted items may be located as not to create additional hazards during the course of the work. If these items are disturbed, lead safe work practices must be followed.</p> <p align="center">*Selected abatement and interim control activities should be completed by a certified abatement contractor or when appropriate a certified renovation firm. After completing these activities, complete and thorough cleaning must be performed following EPA/HUD "Lead Safe Work Practices Procedures". Additionally, after all work has been completed, a final lead clearance should be conducted and may be required. It is the responsibility of the person(s) performing the lead hazard control work to ensure that all appropriate procedures and regulations are followed.</p>				
Identified Hazard	Severity	Priority	Abatement Options	Interim Control Options
Closet casings and baseboards represent deteriorated lead paint surface hazards	Low	Low	1) Remove and replace with new components or 2) wet scrape/sand all surfaces, make necessary repairs, stabilize surfaces and encapsulate with a Michigan approved encapsulant or 3) strip all surfaces bare to the substrate (either chemically or using mechanical wet methods), make necessary repairs and recoat.	Wet scrape / sand all surfaces, make necessary repairs, stabilize all surfaces and repaint.
Bedroom 13				
Door, jamb and stops represent deteriorated lead paint friction/impact surface hazards	Medium	Low	1) Remove and replace with new door systems or 2) replace individual lead painted components or 3) strip all surfaces bare to the substrate, stabilize surfaces, and repaint.	1) Refit door to eliminate friction points, wet scrape/sand all surfaces, make necessary repairs, including installation of weatherstripping or other "soft" stop material, stabilize all surfaces and repaint 2) Use friction reduction treatments (jamb liners, weatherstripping, rubber padding, tread covers, etc.) to reduce wear or 3) Wet plane all friction / impact surfaces, wet scrape all remaining surfaces, make necessary repairs, stabilize all surfaces and repaint.
Side c wall, ceiling, closet wall and closet ceiling represent deteriorated lead paint surface hazards	Low	Low	1) Enclose with drywall or other suitable wallboard material or 2) wet scrape/sand all surfaces, make necessary repairs, stabilize surfaces and encapsulate with a Michigan approved encapsulant.	1) Wet scrape / sand all surfaces, make necessary repairs, stabilize all surfaces and repaint or 2) stabilize all surfaces and cover with a suitable wallboard material
Bedroom 14				
Door, jamb and stops represent deteriorated lead paint friction/impact surface hazards	Medium	Low	1) Remove and replace with new door systems or 2) replace individual lead painted components or 3) strip all surfaces bare to the substrate, stabilize surfaces, and repaint.	1) Refit door to eliminate friction points, wet scrape/sand all surfaces, make necessary repairs, including installation of weatherstripping or other "soft" stop material, stabilize all surfaces and repaint 2) Use friction reduction treatments (jamb liners, weatherstripping, rubber padding, tread covers, etc.) to reduce wear or 3) Wet plane all friction / impact surfaces, wet scrape all remaining surfaces, make necessary repairs, stabilize all surfaces and repaint.



During the course of this lead combination investigation:

Lead Based Paint was identified on some components

Lead Based Paint Hazards were identified in some areas

II.) PURPOSE AND SCOPE OF WORK

Attached here within are the results of a lead based paint (LPB) combination inspection and risk assessment (combination survey) performed by Michael Gravlin of ETC - Environmental Services (ETC). This combination survey was performed for Genesee County Land Bank at 2448 Thomas in Flint, MI 48504. The site work was performed on August 1, 2011 by Michael Gravlin. Michael Gravlin is an EPA certified lead risk assessor and has completed the manufacturer's training course regarding radiation safety and x-ray measurement technology.

The purpose of a lead combination survey is to identify any existing lead paint and/or lead hazards that might exist within the residence. The process of identifying all lead based paint in a residence is referred to as a lead inspection while identifying all lead hazards in a residence is a risk assessment. It has become common in the industry to perform both of these services at one time and this is referred to as a lead combination survey. Although this report represents both services, for the purposes of discussion, we will discuss the methods and goals of inspections and risk assessments separately.

A. Lead Inspections

ETC's inspection started by breaking down the dwelling into separate functional areas. For the testing of paint, each functional area was then broken down into different building components, according to the various colors and substrates. Samples were collected using a X-Ray Fluorescence (XRF) analyzer. The XRF uses radioactive cadmium to determine the amount of lead located within each surface tested. At the time of this report, HUD has defined Lead-Based Paint (LBP) as paint with an average concentration of 1.0 mg/cm², or greater using the XRF technology. Test results for this residence that can be compared against the HUD and EPA standards can be found in Appendix A.

In cases where the XRF detected LBP and the paint was in poor condition (cracked, peeling, chalking, etc.) the inspector may recommended further testing be done. Additional samples such as dust wipes, vacuum samples, air samples or soil samples may be warranted in the areas where the paint is poor condition.

B. Lead Risk Assessments

A lead risk assessment attempts to identify lead hazards that may exist within a home. Lead hazards are defined in an important lead regulation called Title X, the Title X definition includes the following six items:

1. Lead paint that is deteriorated (flaking, chipped, peeling, etc.) in poor condition as defined by Title X.
2. Lead paint on a friction surface (i.e. rubbing doors, sliding windows, etc.) where associated dust levels exceed safe limits.
3. Lead paint on an impact surface (i.e. door jambs, stair treads, etc.) where the impact is caused by another building component.
4. Lead paint on a chewable surface (i.e. window sills, shelves, etc.) where there is visible evidence of teeth marks.
5. Lead contaminated dust where levels exceed safe limits.
6. Lead contaminated soils where levels exceed safe limits.

A lead risk assessment attempts to identify hazards by taking a series of dust, soil and deteriorated paint samples and comparing them to associated limits developed by HUD and EPA.

C. Project Limitations and Problems

Throughout the course of any LBP combination there can be a number of problems including: areas or surfaces that could not be tested, inaccessible areas, locked doors, problems due to inclement weather, etc. During this combination there may have been materials or items that could not be tested or sampled. These materials must be assumed to be lead based paint and treated as such. The items / materials that could not be tested and must therefore be assumed to be lead painted include:

- Several window exteriors—See XRF results

There may have also been unusual circumstances for this project that may have affected the project. The unusual circumstances existing at 2448 Thomas included:

- Overall condition of the house is good—fair, house exterior is vinyl sided, windows are vinyl, wood and aluminum, basement windows are steel, rooms 11 Side A west and room 4 side b have fixed/non-opening windows, entry doors are steel pre hung, sliding doors are aluminum, kitchen and bathroom cabinets are prefabricated, rooms 5 and 11 have factory paneling, room 5 has ceiling tiles, room 5 most likely an addition, room 2 an open porch in the past.
- Garage interior was not tested because it's not painted, garage exterior is aluminum sided, entry doors are steel pre hung.

- X-Ray Fluorescence (XRF) is a non-destructive type of paint testing. Inspectors do not remove items that are fastened shut, down, together or otherwise made to impede access. Drop ceiling tiles, furniture, equipment, and other items are not removed by the inspectors, those areas should be made to be accessible to the inspector by the building owner. Excessive storage conditions, deferred cleaning practices, and unsafe building conditions could be cause for a building component to not be tested. If a building component is present but does not show up on the inspection report it should be considered to be lead painted unless it was installed after 1978 or has a factory finish on it.
- It is also possible that wall hangings, flags, banners, pictures wall shelving units and large furniture may hide damage to wall surfaces. If those items are covering up damage, it could change the classification of that component from intact or fair to poor. If this is the case, treat those damaged surfaces as though they are a hazard.
- Bare soil areas will change with usage, weather and other factors beyond the control of the risk assessor who wrote this report.

III.) REGULATORY INFORMATION

A. Title X

In October of 1992 the Residential Lead-Based Paint Hazard Reduction Act was passed. This was a sweeping act aimed at reducing the exposure to Americans to lead hazards. The regulation affected all areas of the population. As part of Title X, many other agencies were charged with responsibilities in assuring the LBP's were addressed. OSHA was required to pass a construction standard, HUD was required to promulgate specific and definitive rules for addressing Public and Indian housing and the EPA was required to pass regulations for real estate disclosure, pre-renovation disclosure, training and certification programs for people working on or with LBP and rules for conducting renovation activities safely following "lead safe work practices". This act is the base from which all other regulations affecting LBP have grown.

B. Department of Housing and Urban Development (HUD) Regulations

By recognizing lead based paint (LBP) as a potential health hazard, HUD became the lead federal agency in the identification of lead hazards and has the primary responsibility to regulate LBP in Public or Indian housing. HUD has generated guidelines and performed extensive research to develop comprehensive requirements for LBP inspections, risk assessments and lead abatement or removal activities. These guidelines are enforceable in Public or Indian housing projects or any other project where HUD funds are dispersed. This includes most community development block grant (CDBG) funds as well as other housing assistance as provided by HUD, VA, etc. These methods represent the "State of the Art" technology for lead activities. At this point, EPA has developed similar rules that are in force in all housing and child occupied facilities and are enforced on a State by State basis.

If the work to be completed on this project is federally, state or locally funded, it is likely the full HUD regulations will apply. HUD program requirements for most projects are determined by the amount of money spent on the project. In general the requirements are:

For all projects where the rehabilitation costs will be between \$0 - \$25,000

Genesee County Land Bank or their contractors (as you determine) may choose any combination of the following three (3) options to address the hazards found in the executive summary.

- all interim control options
- some interim controls and some abatement options
- or all abatement options

Also, please note that anytime even one abatement option is chosen, the contractor and their employees must be fully certified licensed through the State of Michigan – Lead Program to perform any abatement work.

For all projects where the rehabilitation costs will exceed \$25,000

In this case, Genesee County Land Bank or their contractors (as you determine) must chose ONLY abatement options to address the hazards identified.

This has serious repercussions for Genesee County Land Bank as abatement options are almost always more expensive than interim controls and this price difference between \$24,999 and \$25,001 may require large extra lead expenses to the program costs for this property. *You may wish to share this information with all of your selected contractors so they better understand the potential cost increases when their bid price exceeds \$25,000.*

Please note, this is only a general outline and the HUD regulations are very complex. For instance some costs on a project (i.e. the initial risk assessment and final clearance) may not count toward the rehabilitation costs. For further information, refer to the HUD guidelines or contact a ETC representative.

C. Environmental Protection Agency (EPA):

Recently, EPA adopted HUD guidelines for conducting LBP inspections, risk assessments and abatement work practices for lead issues. Both HUD and EPA define Lead-based Paint (LBP) as an average concentration of 1.0 mg/cm² when using XRF technology and 1/2 % by weight when reviewing paint chips.

- EPA Real Estate Disclosure Act: EPA issued a regulation to insure that families receive information necessary to protect themselves from LBP hazards when purchasing, renting or leasing an older home. In order to accomplish this, the EPA required information to be disseminated during real estate transfers. This act requires sellers and landlords to:
 - Disclose all known information on LBP and hazards in the housing.
 - Complete a Federal disclosure form, including a lead warning statement, provide a copy to the purchaser/prospect, and retain it for three years.
 - Provide purchasers/prospective tenants with an EPA pamphlet on lead hazards.
 - Sellers are also required to give purchasers a 10-day opportunity to conduct a LBP inspection or risk assessment before becoming obligated to purchase the housing.

Agents are required to ensure that the seller or leaser comply with these requirements or perform these requirements themselves. Failure of the seller, leaser, or agent to comply could result in being sued for damages, and being subjected to civil and criminal penalties, such as potential fines and imprisonment.

- EPA Pre-Renovation Rule (PRE): Additionally, EPA issued a regulation to insure contractors warn occupants considering construction within their residence of the possibility that lead dust could be created and work with the selected contractor to reduce this possibility. This act requires renovation contractors of older homes to:
 - Discuss information on LBP and hazards that could be created during a renovation project.
 - Provide purchasers/prospective tenants with an EPA pamphlet on lead hazards and get a signature or other evidence of delivery.
 - This regulation also recommended that all renovations in older housing be completed by trained persons following lead safe work practices.
- EPA Renovation, Repair and Painting Rule (RRP): The most recent EPA regulation (April 2010) regarding LBP was the RRP. This regulation substantially changed requirements for all contractors performing renovations in older housing. This act requires renovation contractors of older homes to:
 - Requires all contractors to have a “certified renovator” working on each project to insure that the regulation is followed. Must be on-site during set-up, cleaning and self conducted clearance.
 - Certified renovators must take an 8 hour training class to receive their certification directly from the EPA.
 - Not only do individuals have to become certified, the companies taking contracts for work need to become “Certified Firms”. This involves applying to the EPA and paying a fee.
 - All work on any affected project must be done following lead safe work practices as taught in the class.
 - Requires posting of work area and possibly containment of work space.
 - Requires a final visual wipe test clearance be performed by the “Certified Renovator”. No neutral third party clearance is required but can be done if desired.

D. Occupational Safety and Health Administration (OSHA):

Additionally, OSHA has established regulations to prevent high lead exposure to employees working in lead related occupations. Along with establishing a permissible exposure limit (PEL), OSHA, working with the National Institute for Occupational Safety and Health (NIOSH), has mandated engineering, work practice and administrative controls to protect the worker. The current PEL at the time of this report is a concentration no greater than 50 micrograms per cubic meter of air.

E. City of Detroit (Ordinances and Codes)

The purpose and intent of the proposed amendments is to protect the health and welfare of children who occupy rented residential dwellings that contain lead-based paint hazards. Part II of this division requires owners of rental property to have a lead inspection and risk assessment performed at the rental property to determine the presence of lead paint and lead-based paint hazards. If lead based paint hazards exist, then the hazards must be reduced and controlled through interim controls or abatement prior to a tenant occupying the rental property. After interim controls or abatement are performed, the owner must obtain a clearance examination. Owners of rental property must obtain a lead clearance pursuant to Part II in order to receive a certificate of compliance from the City. A certificate of compliance is required for occupancy.

IV.) SAMPLE RESULTS AND INFORMATION

A. Lead Paint Sampling

Lead paint sample results are contained in Appendix B. All types of painted surfaces were tested using X-Ray fluorescence (XRF) technologies. XRF uses gamma photons from a sealed irradiation source to strike the atoms within the painted surface. Most commonly, an isotope of cobalt or cadmium is used to produce gamma photons. Because the source is radioactive, training and certification is required to operate an XRF lead analyzer. All inspectors have received the EPA three day lead inspection training and the manufacturer's XRF training. The radiation safety officer for ETC is Jeremy Westcott.

The serial number of the XRF instrument utilized in this project was 19124. These instruments are registered as radioactive materials with the State of Michigan Department of Environmental Quality. The registration number for these instruments is 031070-01-l01. ETC's representatives handle and operate the XRF instrument in accordance with the manufacturers' directives and methods described in the HUD Guidelines.

ETC's lead testing results are applicable for the time that testing was conducted and for the condition of surfaces at the time they were tested. If questions arise regarding lead content on surfaces that were not tested (or were inaccessible) by ETC, then additional testing services should be solicited to test those surfaces for lead.

B. Lead Dust Sampling

For combination surveys, lead dust sampling is required in areas where children are most likely to come into contact with dust. Areas for consideration include: children's bedroom (s), family rooms, play rooms, kitchens, bathrooms, etc. Lead dust samples are to be taken from at least six different rooms with samples from both the floor and either a window sill or window well within each room.

Current limits for lead dust samples taken during combination surveys are as follows in micrograms per square foot ($\mu\text{g}/\text{ft}^2$):

	Floors	Window Sills	Window Wells/ Troughs	Ext. Concrete
HUD	40	250	400	800
EPA	40	250	400	800
OSHA	~9000	~9000	~9000	~9000

Actual dust level results noted at the 2448 Thomas residence are below. Any sample above the allowable regulatory limit is in bold.

<i>Sample #</i>	<i>Room Location</i>	<i>Component</i>	<i>Area Wiped (in sq. ft.)</i>	<i>Lead Concentration (in $\mu\text{g}/\text{ft}^2$)</i>
WS 1	Sunroom 2	Floor	1.00	213.00
WS 2	Sunroom 2 side a	Window sill	0.49	583.00
WS 3	Living room 3	Floor	1.00	19.60
WS 4	Living room 3 side b	Trough	0.91	1615.00
WS 5	Kitchen 6	Floor	1.00	84.60
WS 6	Kitchen 6 side d	Window sill	0.54	2647.00
WS 7	Bedroom 12	Floor	1.00	< 10
WS 8	Bedroom 12 side a	Trough	0.63	265.00
WS 9	Bedroom 13	Floor	1.00	132.00
WS 10	Bedroom 13 side b	Window sill	0.70	43.20
WS 11	Bedroom 14	Floor	1.00	< 10
WS 12	Bedroom 14 side c	Trough	0.63	103.00

Any high dust levels noted here represent lead hazards and are included in the hazard charts in the Executive Summary. This chart details the lead dust problems identified (or lack thereof) within this residence. *Please keep in mind that if lead dust samples were not taken in each room of the residence the samples that were taken will be used to represent overall conditions in the residence.* This means that areas that were not individually sampled may be listed as having problems based upon the sampling that was conducted in other areas.

C. Lead Soil Sampling

Lead soil sampling is required in areas where bare exposed soil is present around the house and the yard. Areas for consideration include: house perimeter, gardens, play areas, driveways, etc. Lead soil samples will only be taken if bare exposed soils exist. Sampling usually involves three areas: play areas where children are likely to come in contact with soil, the perimeter of the home (i.e. gardens, etc.) and other non-play areas of the yard where contact is less likely.

Current limits for lead soil samples taken during combination surveys are as follows in parts per million (ppm):

	Play Areas	House Perimeter or Other Areas of Yard
HUD	400	1200
EPA	400	1200

Actual soil results for the 2448 Thomas residence can be found in the chart below. Any sample above the allowable regulatory limit is in bold.

	Location	Results (parts per million)
SS-1	Perimeter of House	227

Any high soil levels noted here represent lead hazards and are included in the hazard charts in the Executive Summary. This chart details the lead soil problems identified (or lack thereof) within this residence. Please keep in mind that lead soil samples are composite samples where a small portion is taken from four or five different locations to make up the one sample. Therefore the results of this one sample represent all of the different areas where the separate pieces were acquired. Play areas and non-play areas should never be mixed in the same sample

V.) HAZARD CONTROL OPTION RECOMMENDATIONS

Types of hazards that may have been identified during the lead combination include both identified hazards and potential hazards. Identified hazards include paint, dust and soil hazards that fit the six (6) hazard definitions of HUD and the EPA detailed above. For each identified hazard, hazard control options (recommendations) are given to explain how to address any problems identified in the sampling. In the case of the 2448 Thomas property, hazard control options can be found in the Executive Summary Chart.

Potential hazards are areas of the residence where the occupant or owner may be completing renovation activities in the future. If future renovation activities were identified, these areas were sampled using the XRF instrument to determine lead content. If the paint in these areas was found to be above 1.0 mg/cm^2 , they were listed as potential hazards. This is required as the up-coming renovation activities will likely disturb the paint and possibly create lead based dust hazards that do not currently exist. It is critical that the homeowner (or selected renovation contractor) follow "lead safe work practices" when working on the potential hazards to avoid creating lead dust hazards. A list of potential hazards identified during the combination can be found in Appendix C.

VI.) RE-EVALUATION RECOMMENDATIONS

Anytime lead paint or hazards remain in the building and are not completely removed, the risk assessor is required to make recommendations for re-evaluating the building. This is the recommended time when the homeowner should hire a certified risk assessor to determine whether (1) conditions at the home have changed possibly causing additional hazards, (2) the initial hazard control options implemented have been effective or (3) if further work is warranted. The frequency of re-evaluations recommended is dependent on both the risk assessment results and the hazard control options that are chosen and implemented.

At the time of producing this risk assessment, the risk assessor can only be sure of the current conditions, but can not know for sure which hazard control options will be selected. For this reason, ETC has chosen to include a re-evaluation chart in Appendix F. To determine the re-evaluation frequency recommended for this residence, please refer to this chart and reference Schedule 3 as given in the chart. This schedule was chosen based upon the results of the initial risk assessment. After finding the appropriate schedule, the homeowner / building manager / owner will need to know which hazard control options were conducted. By knowing the appropriate schedule (Schedule 3) and the hazard control selected (chosen by the owner) you can determine the recommended re-evaluation frequency.

If you do not wish to follow the chart, you can opt to follow the most stringent re-evaluation frequency that would be to re-evaluate at: 6 months, then 1 year then 2 years.

VII.) COST ESTIMATE

HUD and EPA regulations require the risk assessor to provide cost estimates for possible work to be completed. Below find a rough estimate of costs associated with lead remediation activities.

Encapsulation	\$3.50 sq. ft.	Enclosure wood	\$4.00 sq. ft.
Wet plane friction & impact points	\$2.50 sq. ft.	Enclosure metal	\$5.00 sq. ft.
Wet scrape and repaint	\$2.00 sq. ft.	Enclosure drywall	\$2.50 sq. ft.
Window replacement	\$500 each	Door replacement	\$750.00 each.
Dust removal-clean up	\$1.25 sq. ft.	Soil abatement	\$10.00 sq. ft.
Siding Installation	\$2.75 sq. ft.	Component replacement	5 times material cost

VIII.) RECOMMENDATIONS FOR FUTURE OPERATIONS AND MAINTENANCE

It is very important to note that future disturbance of lead painted surfaces may cause new and additional lead hazards. Homeowners, building managers and landlords are expected to follow "lead safe work practices" any time that a lead painted surface is disturbed. This means making sure very little dust is generated (i.e. wet sanding not dry sanding), not burning lead painted items, cleaning up thoroughly after work, etc.

In order to provide guidance for the owners, managers and landlords when conducting renovation, maintenance or potential future disturbance of painted surfaces, they should refer to an excellent manual developed by HUD titled "Lead Paint Safety: A Field Guide for Painting, Home Maintenance, and Renovation Work". This manual can be found for free on the Internet at <http://www.hud.gov/offices/lead/training/LBPguide.pdf>. Please download a copy of this manual before disturbing any painted surfaces within the residence. If access to the Internet is not available, you may order a copy at 1-800-424-5323.

If you have any questions not answered by this manual, please contact our office at (734) 955-6600. Thank you.

This report reviewed and submitted by

ETC – Environmental Services

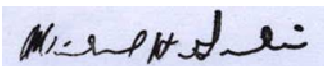

Michael Gravlin (Cert. # P-00313)
EPA / Michigan Certified Risk Assessor

ETC - Environmental Services WILCO Environmental

APPENDIX A

All Paint Samples Taken - In Order Sampled

Please note: Post 1978 Construction, factory finished and unpainted items were not sampled

Client		Genesee County Land Bank										
Survey Location:		2448 Thomas St., Flint, MI 48504										
Survey Date:		08/01/11										
Inspectors:		Michael Gravlin			License #	P-00313			Job#	137854		
Sample #	Floor	Wall / Side	Room and #	Component	Substrate	Visual Condition	Color	Note	Depth Index	Result	mg/cm ² +/- Precision	
1										Positive	7.11 +/- 0	
2			CALIBRATE						2.82	Positive	1.2 +/- 0.2	
3			CALIBRATE						1.05	Negative	0.9 +/- 0.1	
4			CALIBRATE						1.09	Positive	1 +/- 0.1	
5	First	A	Foyer 1	Wall	Plaster	FAIR	White		6.16	Negative	0.6 +/- 0.4	
6	First	B	Foyer 1	Wall	Plaster	FAIR	White		10	Negative	0.5 +/- 0.5	
7	First	C	Foyer 1	Wall	Plaster	FAIR	White		6.05	Negative	0.14 +/- 0.21	
8	First	D	Foyer 1	Wall	Plaster	FAIR	White		7.66	Negative	0.24 +/- 0.75	
9	First	Ceiling	Foyer 1	Ceiling	Plaster	FAIR	White		5.3	Negative	0.02 +/- 0.07	
10	First	D	Foyer 1	Baseboard	Wood	FAIR	White		4.23	Negative	0.06 +/- 0.15	
11	First	D	Foyer 1	Win. Apron	Wood	INTACT	White		5.64	Negative	0.08 +/- 0.36	
12	First	D	Foyer 1	Win. Sill/Stool	Wood	FAIR	White		2.08	Negative	0.02 +/- 0.1	
13	First	D	Foyer 1	Win. Casing	Wood	FAIR	White		2.46	Negative	0.03 +/- 0.14	
14	First	D	Foyer 1	Win. Stop	Wood	FAIR	White		6.02	Negative	0.08 +/- 0.38	
15	First	D	Foyer 1	Win. Sash	Wood	FAIR	White		1.61	Negative	0.01 +/- 0.08	
16	First	A	Foyer 1	Door Casing	Wood	FAIR	White		1.33	Negative	0.01 +/- 0.06	
17	First	A	Foyer 1	Door Jamb	Wood	POOR	White		1	Negative	0 +/- 0.02	
18	First	A	Foyer 1	Entry Door	Metal	POOR	White		1	Negative	0 +/- 0.03	
19	First	A	Foyer 1	Entry Door	Metal	POOR	Red		1	Negative	0 +/- 0.02	
20	First	B	Foyer 1	Clos. Casing	Wood	FAIR	White		1.36	Negative	0.01 +/- 0.06	
21	First	B	Foyer 1	Clos. Jamb	Wood	FAIR	White		1	Negative	0.02 +/- 0.06	
22	First	B	Foyer 1	Clos. Stop	Wood	FAIR	White		1.92	Negative	0.02 +/- 0.11	
23	First	B	Foyer 1	Clos. Door	Wood	POOR	White		6.58	Negative	0.09 +/- 0.41	
24	First	B	Foyer 1	Clos. Baseboard	Wood	FAIR	Clear / Stain		1	Negative	0.01 +/- 0.05	
25	First	B	Foyer 1	Clos. Shelf	Wood	FAIR	Clear / Stain		1	Negative	0.01 +/- 0.04	
26	First	B	Foyer 1	Shelf Bracket	Wood	FAIR	Clear / Stain		1	Negative	0 +/- 0.02	
27	First	B	Foyer 1	Clos. Wall	Plaster	FAIR	White		3.04	Negative	0.04 +/- 0.08	
28	First	B	Foyer 1	Clos. Ceiling	Plaster	FAIR	White		1	Negative	0.01 +/- 0.03	
29	First	C	Foyer 1	Newel Post	Wood	FAIR	White		3.62	Negative	0.02 +/- 0.14	
30	First	C	Foyer 1	Railing Cap	Wood	FAIR	White		1	Negative	0.01 +/- 0.05	
31	First	C	Foyer 1	Baluster	Wood	FAIR	White		1	Negative	0 +/- 0.03	
32	First	Floor	Foyer 1	Floor Register	Metal	FAIR	Black		1	Negative	0 +/- 0.02	
33	First	Floor	Foyer 1	Floor Register	Wood	FAIR	Black		1	Negative	0.01 +/- 0.03	
34	First	C	Living Room 3	Floor Register	Wood	FAIR	Black		3.12	Negative	0.05 +/- 0.2	
35	First	C	Living Room 3	Wall Register	Metal	FAIR	White		6.45	Negative	-0.18 +/- 1.16	
36	First	A	Sun Room 2	Wall	Wood	FAIR	White		3.59	Negative	0.4 +/- 0.4	
37	First	B	Sun Room 2	Wall	Wood	FAIR	White		5.03	Negative	0.8 +/- 0.2	

ETC - Environmental Services WILCO Environmental

APPENDIX A

All Paint Samples Taken - In Order Sampled

Please note: Post 1978 Construction, factory finished and unpainted items were not sampled

Client		Genesee County Land Bank										
Survey Location:		2448 Thomas St., Flint, MI 48504										
Survey Date:		08/01/11										
Inspectors:		Michael Gravlin			License #	P-00313			Job#	137854		
Sample #	Floor	Wall / Side	Room and #	Component	Substrate	Visual Condition	Color	Note	Depth Index	Result	mg/cm ² +/- Precision	
38	First	Ceiling	Sun Room 2	Ceiling	Wood	FAIR	White		4.65	Positive	3 +/- 1.5	
39	First	A	Sun Room 2	Beam	Wood	FAIR	White		9.46	Positive	3.4 +/- 2.1	
40	First	A	Sun Room 2	Crown Molding	Wood	POOR	White		9.86	Positive	2.7 +/- 1.5	
41	First	A	Sun Room 2	Win. Mullion	Wood	FAIR	White		10	Positive	3.3 +/- 1.8	
42	First	A	Sun Room 2	Win. Sill/Stool	Wood	POOR	White		3.7	Positive	2.8 +/- 1.5	
43	First	A	Sun Room 2	Win. Jamb	Wood	POOR	White		10	Positive	9.7 +/- 6.2	
44	First	A	Sun Room 2	Win. Well/Trough	Wood	POOR	White		10	Positive	10.8 +/- 9.3	
45	First	C	Sun Room 2	Door Casing	Wood	FAIR	White		6.91	Positive	15.9 +/- 12.5	
46	First	C	Sun Room 2	Door Jamb	Wood	POOR	White		4.8	Positive	10.6 +/- 6.1	
47	First	C	Sun Room 2	Door	Wood	POOR	White		10	Positive	15 +/- 11.5	
48	First	C	Sun Room 2	Door	Wood	POOR	White		1	Negative	0 +/- 0.04	
49	First	C	Sun Room 2	Door Threshold	Wood	POOR	Grey		2.8	Positive	7 +/- 5.6	
50	First	Floor	Sun Room 2	Floor	Concrete	POOR	Grey		2.39	Positive	2.2 +/- 0.8	
51	First	A	Living Room 3	Wall	Plaster	POOR	White		5.42	Negative	0.3 +/- 0.69	
52	First	B	Living Room 3	Wall	Plaster	FAIR	White		2.3	Negative	0.01 +/- 0.02	
53	First	C	Living Room 3	Wall	Plaster	FAIR	White		1	Negative	0 +/- 0.02	
54	First	D	Living Room 3	Wall	Plaster	FAIR	White		7.67	Negative	0.03 +/- 0.07	
55	First	Ceiling	Living Room 3	Ceiling	Plaster	FAIR	White		3.35	Negative	0.01 +/- 0.04	
56	First	D	Living Room 3	Chimney	Plaster	POOR	White		1	Negative	0 +/- 0.02	
57	First	D	Living Room 3	Fire Mantle	Wood	FAIR	Red		1	Negative	0 +/- 0.03	
58	First	D	Living Room 3	Fireplace	Brick	FAIR	Red		1	Negative	0 +/- 0.02	
59	First	A	Living Room 3	Door Casing	Wood	POOR	White		2.43	Negative	0.02 +/- 0.12	
60	First	A	Living Room 3	Door Jamb	Wood	POOR	White		1	Negative	0 +/- 0.03	
61	First	A	Living Room 3	Door Stop	Wood	POOR	White		1.58	Negative	0.02 +/- 0.09	
62	First	B	Living Room 3	Baseboard	Wood	FAIR	White		4.59	Negative	0.03 +/- 0.19	
63	First	B	Living Room 3	Crown Molding	Wood	FAIR	White		1	Negative	0 +/- 0.02	
64	First	B	Living Room 3	Win. Apron	Wood	FAIR	White		2.77	Negative	0.04 +/- 0.16	
65	First	B	Living Room 3	Win. Sill/Stool	Wood	FAIR	White		7.11	Negative	0.11 +/- 0.24	
66	First	B	Living Room 3	Win. Casing	Wood	FAIR	White		6.27	Negative	0.06 +/- 0.3	
67	First	B	Living Room 3	Win. Stop	Wood	FAIR	White		4.47	Negative	0.05 +/- 0.24	
68	First	B	Living Room 3	Win. Sash	Wood	FAIR	White		1.51	Negative	0.02 +/- 0.08	
69	First	B	Living Room 3	Win. Sash, ext.	Wood	POOR	White		4.62	Positive	4.7 +/- 2.8	
70	First	B	Living Room 3	Win. Well/Trough	Wood	POOR	White		7.53	Positive	18.3 +/- 12.9	
71	First	B	Living Room 3	Win. Jamb	Wood	POOR	White		5.69	Positive	19.1 +/- 13.2	
72	First	A	Dining Room 4	Wall	Wood	FAIR	White		1	Negative	0 +/- 0.02	
73	First	B	Dining Room 4	Wall	Wood	POOR	White		2.98	Negative	0.01 +/- 0.03	
74	First	C	Dining Room 4	Wall	Wood	FAIR	White		9.64	Negative	0.26 +/- 0.71	

ETC - Environmental Services WILCO Environmental

APPENDIX A

All Paint Samples Taken - In Order Sampled

Please note: Post 1978 Construction, factory finished and unpainted items were not sampled

Client		Genesee County Land Bank										
Survey Location:		2448 Thomas St., Flint, MI 48504										
Survey Date:		08/01/11										
Inspectors:		Michael Gravlin			License #	P-00313			Job#	137854		
Sample #	Floor	Wall / Side	Room and #	Component	Substrate	Visual Condition	Color	Note	Depth Index	Result	mg/cm ² +/- Precision	
75	First	D	Dining Room 4	Wall	Wood	FAIR	White		1	Negative	0 +/- 0.02	
76	First	Ceiling	Dining Room 4	Ceiling	Wood	FAIR	White		1	Negative	0 +/- 0.02	
77	First	D	Dining Room 4	Wall Register	Metal	FAIR	White		4.16	Negative	-0.17 +/- 0.79	
78	First	D	Dining Room 4	Baseboard	Wood	FAIR	White		1	Negative	0 +/- 0.02	
79	First	D	Dining Room 4	Door Casing	Wood	FAIR	White		4.04	Negative	0.04 +/- 0.22	
80	First	D	Dining Room 4	Door Jamb	Wood	FAIR	White		1.89	Negative	0.01 +/- 0.09	
81	First	B	Dining Room 4	Win. Apron	Wood	FAIR	White		1	Negative	0.01 +/- 0.04	
82	First	B	Dining Room 4	Win. Sill/Stool	Wood	FAIR	White		2.56	Negative	0.03 +/- 0.14	
83	First	B	Dining Room 4	Win. Casing	Wood	FAIR	White		1	Negative	0 +/- 0.03	
84	First	B	Dining Room 4	Win. Sash	Wood	FAIR	White		2.91	Negative	0.02 +/- 0.13	
85	First	C	Dining Room 4	Door Casing	Wood	FAIR	White		1	Negative	0 +/- 0.02	
86	First	Ceiling	Mud Room 5	Ceiling	Wood	POOR	White		1	Negative	0 +/- 0.03	
87	First	Ceiling	Mud Room 5	Joist	Wood	FAIR	White		1	Negative	0 +/- 0.04	
88	First	Ceiling	Mud Room 5	Soffit	Wood	POOR	Blue		3.92	Positive	31 +/- 18.9	
89	First	A	Mud Room 5	Door Casing	Wood	POOR	Clear / Stain		1	Negative	0 +/- 0.03	
90	First	A	Kitchen 6	Wall	Wood	FAIR	Paper		1.87	Negative	0.14 +/- 0.25	
91	First	A	Kitchen 6	Wall	Plaster	FAIR	Paper		7.84	Negative	0.4 +/- 0.2	
92	First	B	Kitchen 6	Wall	Plaster	FAIR	Paper		7.62	Negative	0.27 +/- 0.15	
93	First	C	Kitchen 6	Soffit	Plaster	FAIR	Paper		1	Negative	0 +/- 0.02	
94	First	D	Kitchen 6	Wall	Plaster	FAIR	Paper		6.94	Negative	0.3 +/- 0.2	
95	First	Ceiling	Kitchen 6	Ceiling	Plaster	POOR	White		6.27	Negative	0.4 +/- 0.6	
96	First	D	Kitchen 6	Baseboard	Wood	FAIR	White		7.71	Negative	0.7 +/- 0.2	
97	First	D	Kitchen 6	Win. Apron	Wood	FAIR	White		1	Negative	0 +/- 0.03	
98	First	D	Kitchen 6	Win. Sill/Stool	Wood	FAIR	White		1	Negative	0 +/- 0.02	
99	First	D	Kitchen 6	Win. Casing	Wood	FAIR	White		5.4	Positive	1.5 +/- 0.4	
100	First	D	Kitchen 6	Win. Stop	Wood	FAIR	White		4.15	Negative	0.3 +/- 0.16	
101	First	D	Kitchen 6	Win. Sash	Wood	POOR	White		7.01	Positive	1.5 +/- 0.5	
102	First	D	Kitchen 6	Win. Sash, ext.	Wood	POOR	White		2.38	Positive	1.6 +/- 0.5	
103	First	D	Kitchen 6	Win. Jamb	Wood	POOR	White		4.02	Positive	15 +/- 11.9	
104	First	D	Kitchen 6	Win. Well/Trough	Wood	POOR	White		4.65	Positive	13.7 +/- 10.7	
105	First	A	Kitchen 6	Door Casing	Wood	FAIR	White		10	Positive	1.2 +/- 0.2	
106	First	A	Kitchen 6	Door Jamb	Wood	FAIR	White		6.55	Negative	0.3 +/- 0.16	
107	First	D	Kitchen 6	Wall Register	Metal	FAIR	White		3.36	Negative	0.15 +/- 0.35	
108	First	C	Kitchen 6	Win. Casing	Metal	FAIR	White		1	Negative	0 +/- 0.02	
109	First	C	Kitchen 6	Win. Sash	Wood	FAIR	White		1	Negative	0 +/- 0.02	
110	First	B	Basment Stair 7	Wall	Wood	FAIR	White		10	Negative	-0.09 +/- 0.71	
111	First	C	Basment Stair 7	Wall	Wood	FAIR	White		10	Positive	2.1 +/- 0.9	

ETC - Environmental Services WILCO Environmental

APPENDIX A

All Paint Samples Taken - In Order Sampled

Please note: Post 1978 Construction, factory finished and unpainted items were not sampled

Client		Genesee County Land Bank										
Survey Location:		2448 Thomas St., Flint, MI 48504										
Survey Date:		08/01/11										
Inspectors:		Michael Gravlin			License #	P-00313			Job#	137854		
Sample #	Floor	Wall / Side	Room and #	Component	Substrate	Visual Condition	Color	Note	Depth Index	Result	mg/cm ² +/- Precision	
112	First	D	Basment Stair 7	Wall	Wood	FAIR	White		10	Positive	2 +/- 0.9	
113	First	Ceiling	Basment Stair 7	Ceiling	Plaster	POOR	White		10	Positive	1.4 +/- 0.4	
114	First	D	Basment Stair 7	Door Casing	Wood	FAIR	White		7.33	Negative	0.13 +/- 0.54	
115	First	D	Basment Stair 7	Door Jamb	Wood	POOR	White		6.87	Positive	18.9 +/- 13.5	
116	First	D	Basment Stair 7	Door Threshold	Wood	POOR	White		1.44	Negative	0.3 +/- 0.34	
117	First	D	Basment Stair 7	Entry door	Metal	POOR	White		1	Negative	0 +/- 0.02	
118	First	D	Basment Stair 7	Ledge	Wood	POOR	Grey		5.03	Positive	1.7 +/- 0.6	
119	First	D	Basment Stair 7	Wall Casing	Wood	FAIR	White		1	Negative	0 +/- 0.03	
120	First	D	Basment Stair 7	Wall, Lower	Wood	POOR	White		1	Negative	0 +/- 0.03	
121	First	B	Basment Stair 7	Wall, Lower	Wood	POOR	White		6.32	Positive	1.5 +/- 0.5	
122	First	B	Basment Stair 7	Railing Cap	Wood	POOR	Grey		1	Negative	0 +/- 0.03	
123	Exterior	B	Basment Stair 7	Newel Post	Wood	POOR	Grey		1	Negative	0 +/- 0.03	
124	Exterior	B	Basment Stair 7	Stair Stringer	Wood	FAIR	Grey		3.26	Positive	4.6 +/- 2.8	
125	Exterior	Floor	Basment Stair 7	Stair Tread	Wood	FAIR	Grey		5.49	Positive	11.7 +/- 10.5	
126	Exterior	Floor	Basment Stair 7	Stair Riser	Wood	FAIR	Grey		1	Negative	0 +/- 0.03	
127	Exterior	A	Basement 8	Wall	Cinder Block	POOR	White		1	Negative	0 +/- 0.02	
128	Exterior	B	Basement 8	Wall	Cinder Block	POOR	White		1.46	Negative	0.01 +/- 0.02	
129	Exterior	C	Basement 8	Wall	Cinder Block	POOR	White		1.79	Negative	0.01 +/- 0.02	
130	Exterior	D	Basement 8	Wall	Cinder Block	POOR	White		1	Negative	0 +/- 0.02	
131	Exterior	A	Basement 8	Stair Wall	Wood	POOR	White		1	Negative	0 +/- 0.03	
132	Exterior	D	Basement 8	Wall	Wood	POOR	White		1	Negative	0 +/- 0.02	
133	Exterior	Ceiling	Basement 8	Joist	Wood	POOR	White		1	Negative	0 +/- 0.03	
134	Exterior	Ceiling	Basement 8	Beam	Metal	POOR	White		1.66	Positive	5.3 +/- 3.3	
135	Exterior	Center	Basement 8	Support Pole	Metal	POOR	White		2.04	Positive	5.8 +/- 3.9	
136	Exterior	Center	Basement 8	Pipe/DWV	Metal	POOR	White		3.91	Negative	0.19 +/- 0.44	
137	Exterior	A	Basement 8	Pipe/Gasline	Metal	POOR	White		2.1	Positive	1.2 +/- 0.2	
138	Exterior	B	Basement 8	Clos. Casing	Wood	FAIR	White		1	Negative	0 +/- 0.03	
139	Exterior	B	Basement 8	Clos. Jamb	Wood	FAIR	White		1.04	Negative	0.02 +/- 0.06	
140	Exterior	B	Basement 8	Clos. Wall	Cinder Block	POOR	White		2.55	Negative	0.01 +/- 0.04	
141	Exterior	B	Basement 8	Clos. Wall	Concrete	POOR	White		1.77	Negative	0 +/- 0.02	
142	Exterior	B	Basement 8	Clos. Ceiling	Concrete	POOR	White		1	Negative	0 +/- 0.02	
143	Exterior	D	Basement 8	Chimney	Brick	POOR	White		3.97	Negative	0.11 +/- 0.08	
144	Exterior	D	Basement 8	Win. Sash	Metal	POOR	White		1.23	Negative	0.24 +/- 0.25	
145	Exterior	Floor	Basement 8	Floor	Concrete	POOR	Grey		2.58	Negative	0.02 +/- 0.03	
146	Exterior	D	Basement 8	Win. Casing	Wood	POOR	White		2.51	Negative	0.3 +/- 0.45	
147	First	B	Stair Up 9	Wall	Plaster	FAIR	White		1	Negative	0 +/- 0.02	
148	First	D	Stair Up 9	Wall	Plaster	FAIR	White		2.28	Negative	0.05 +/- 0.08	

ETC - Environmental Services WILCO Environmental

APPENDIX A

All Paint Samples Taken - In Order Sampled

Please note: Post 1978 Construction, factory finished and unpainted items were not sampled

Client		Genesee County Land Bank										
Survey Location:		2448 Thomas St., Flint, MI 48504										
Survey Date:		08/01/11										
Inspectors:		Michael Gravlin			License #	P-00313			Job#	137854		
Sample #	Floor	Wall / Side	Room and #	Component	Substrate	Visual Condition	Color	Note	Depth Index	Result	mg/cm ² +/- Precision	
149	First	Ceiling	Stair Up 9	Ceiling	Plaster	FAIR	White		6.1	Negative	-0.51 +/- 1.39	
150	First	D	Stair Up 9	Stair Stringer	Wood	FAIR	White		2.62	Negative	0.03 +/- 0.13	
151	Second	D	Stair Up 9	Win. Apron	Wood	FAIR	White		1	Negative	0.01 +/- 0.04	
152	Second	D	Stair Up 9	Win. Sill/Stool	Wood	FAIR	White		7.06	Negative	0.1 +/- 0.46	
153	Second	D	Stair Up 9	Win. Casing	Wood	FAIR	White		3.8	Negative	0.05 +/- 0.24	
154	Second	D	Stair Up 9	Win. Stop	Wood	FAIR	White		1.96	Negative	0.03 +/- 0.12	
155	Second	C	Stair Up 9	Baseboard	Wood	FAIR	White		2.06	Negative	0.02 +/- 0.1	
156	Second	B	Stair Up 9	Corner Trim	Wood	FAIR	White		5.03	Negative	0.07 +/- 0.16	
157	Second	A	Hallway 10	Wall	Plaster	FAIR	White		9.21	Negative	0.13 +/- 0.68	
158	Second	B	Hallway 10	Wall	Plaster	FAIR	White		7.21	Negative	0.06 +/- 0.1	
159	Second	C	Hallway 10	Wall	Plaster	FAIR	White		8.39	Negative	0.3 +/- 0.7	
160	Second	D	Hallway 10	Wall	Plaster	FAIR	White		8.46	Negative	0.4 +/- 0.6	
161	Second	Ceiling	Hallway 10	Ceiling	Plaster	FAIR	White		7.72	Negative	0.06 +/- 0.07	
162	Second	Ceiling	Hallway 10	Attic cover casing	Wood	FAIR	White		10	Positive	1.8 +/- 0.8	
163	Second	Ceiling	Hallway 10	Attic Cover	Wood	FAIR	White		10	Positive	2.2 +/- 0.8	
164	Second	D	Hallway 10	Clos. Casing	Wood	POOR	White		10	Positive	2.4 +/- 0.9	
165	Second	D	Hallway 10	Clos. Jamb	Wood	POOR	Pink		4	Positive	1.5 +/- 0.4	
166	Second	D	Hallway 10	Clos. Stop	Wood	FAIR	Pink		2.67	Positive	2 +/- 0.9	
167	Second	D	Hallway 10	Clos. Baseboard	Wood	FAIR	Pink		2.16	Positive	2 +/- 0.7	
168	Second	D	Hallway 10	Clos. Shelf	Wood	FAIR	White		3.72	Positive	1.8 +/- 0.7	
169	Second	D	Hallway 10	Shelf Bracket	Wood	FAIR	White		5.34	Positive	1.6 +/- 0.5	
170	Second	D	Hallway 10	Clos. Wall	Plaster	FAIR	White		1.45	Negative	0.16 +/- 0.14	
171	Second	D	Hallway 10	Clos. Ceiling	Plaster	FAIR	White		1.63	Negative	0.14 +/- 0.12	
172	Second	B	Hallway 10	Door Casing	Wood	POOR	White		10	Positive	1.8 +/- 0.8	
173	Second	B	Hallway 10	Door Jamb	Wood	POOR	White		10	Positive	2 +/- 0.7	
174	Second	C	Hallway 10	Baseboard	Wood	FAIR	White		9.57	Positive	1.5 +/- 0.5	
175	Second	C	Hallway 10	Baseboard	Wood	FAIR	White		1	Negative	0.01 +/- 0.04	
176	Second	A	Bathroom 11	Wall	Plaster	FAIR	Blue		6.85	Negative	0.6 +/- 0.1	
177	Second	B	Bathroom 11	Wall	Plaster	FAIR	Paper		5.17	Negative	0.5 +/- 0.1	
178	Second	C	Bathroom 11	Wall	Plaster	FAIR	Paper		5.6	Negative	0.6 +/- 0.1	
179	Second	D	Bathroom 11	Wall	Plaster	FAIR	Paper		7.65	Negative	0.6 +/- 0.3	
180	Second	D	Bathroom 11	Partition	Plaster	FAIR	Paper		3.84	Negative	0.24 +/- 0.13	
181	Second	Ceiling	Bathroom 11	Ceiling	Plaster	FAIR	White		10	Negative	0.9 +/- 0.2	
182	Second	A	Bathroom 11	Win. Apron	Wood	FAIR	White		10	Positive	2.5 +/- 1.3	
183	Second	A	Bathroom 11	Win. Sill/Stool	Wood	FAIR	White		6.23	Positive	1.7 +/- 0.7	
184	Second	A	Bathroom 11	Win. Casing	Wood	FAIR	White		7.01	Positive	2.4 +/- 1.3	
185	Second	A	Bathroom 11	Win. Sash	Wood	FAIR	White		10	Positive	1.8 +/- 0.7	

ETC - Environmental Services WILCO Environmental

APPENDIX A

All Paint Samples Taken - In Order Sampled

Please note: Post 1978 Construction, factory finished and unpainted items were not sampled

Client		Genesee County Land Bank										
Survey Location:		2448 Thomas St., Flint, MI 48504										
Survey Date:		08/01/11										
Inspectors:		Michael Gravlín			License #	P-00313			Job#	137854		
Sample #	Floor	Wall / Side	Room and #	Component	Substrate	Visual Condition	Color	Note	Depth Index	Result	mg/cm ² +/- Precision	
186	Second	A	Bathroom 11	Win. Sash, ext.	Wood	POOR	White		4.79	Positive	3.8 +/- 1.9	
187	Second	A	Bathroom 11	Win. Well/Trough	Wood	POOR	White		8.46	Positive	16.3 +/- 12.3	
188	Second	A	Bathroom 11	Win. Jamb	Wood	POOR	White		10	Positive	19.4 +/- 13.8	
189	Second	C	Bathroom 11	Door Casing	Wood	FAIR	White		10	Positive	1.9 +/- 0.8	
190	Second	C	Bathroom 11	Door Jamb	Wood	POOR	White		10	Positive	1.8 +/- 0.8	
191	Second	C	Bathroom 11	Door Stop	Wood	POOR	White		8.45	Positive	2.8 +/- 1.8	
192	Second	C	Bathroom 11	Door	Wood	POOR	White		10	Positive	1.4 +/- 0.4	
193	Second	D	Bedroom 12	Door	Wood	POOR	White		8.25	Positive	1.7 +/- 0.7	
194	Second	D	Bedroom 12	Door Jamb	Wood	POOR	White		4.37	Positive	2.6 +/- 1.4	
195	Second	D	Bedroom 12	Door Stop	Wood	POOR	White		10	Positive	2.1 +/- 0.8	
196	Second	D	Bedroom 12	Door Casing	Wood	POOR	White		7.55	Positive	2.9 +/- 1.7	
197	Second	D	Bedroom 12	Wall Register	Metal	FAIR	White		1.11	Negative	0.01 +/- 0.03	
198	Second	D	Bedroom 12	Baseboard	Wood	FAIR	White		10	Positive	2.5 +/- 1.4	
199	Second	A	Bedroom 12	Win. Apron	Wood	FAIR	White		10	Positive	2.2 +/- 0.8	
200	Second	A	Bedroom 12	Win. Sill/Stool	Wood	FAIR	White		10	Positive	3 +/- 1.7	
201	Second	A	Bedroom 12	Win. Casing	Wood	FAIR	White		10	Positive	2.9 +/- 1.8	
202	Second	A	Bedroom 12	Win. Stop	Wood	POOR	White		8.71	Positive	3 +/- 1.9	
203	Second	B	Bedroom 12	Clos. Door	Wood	POOR	White		10	Positive	1.9 +/- 0.7	
204	Second	B	Bedroom 12	Clos. Casing	Wood	FAIR	White		10	Positive	2.8 +/- 1.7	
205	Second	B	Bedroom 12	Clos. Jamb	Wood	POOR	White		5.5	Positive	3.3 +/- 2.2	
206	Second	B	Bedroom 12	Clos. Stop	Wood	POOR	White		6.2	Positive	2.5 +/- 1.4	
207	Second	B	Bedroom 12	Clos. Baseboard	Wood	POOR	White		8.44	Positive	1.9 +/- 0.8	
208	Second	B	Bedroom 12	Clos. Shelf	Wood	FAIR	White		1	Negative	0 +/- 0.02	
209	Second	B	Bedroom 12	Shelf Bracket	Wood	FAIR	White		1	Negative	0 +/- 0.03	
210	Second	B	Bedroom 12	Clos. Wall	Plaster	POOR	White		3.43	Negative	0.07 +/- 0.07	
211	Second	B	Bedroom 12	Clos. Ceiling	Plaster	FAIR	White		4.1	Negative	0.09 +/- 0.13	
212	Second	A	Bedroom 12	Wall	Plaster	FAIR	White		5.77	Negative	0.05 +/- 0.15	
213	Second	B	Bedroom 12	Wall	Plaster	FAIR	White		4.09	Negative	0.22 +/- 0.75	
214	Second	C	Bedroom 12	Wall	Plaster	FAIR	White		7.77	Negative	0.05 +/- 0.14	
215	Second	D	Bedroom 12	Wall	Plaster	FAIR	White		2.43	Negative	0.5 +/- 0.5	
216	Second	Ceiling	Bedroom 12	Ceiling	Plaster	FAIR	White		9.17	Negative	0.4 +/- 0.6	
217	Second	Ceiling	Bedroom 12	Ceiling	Plaster	FAIR	White		6.07	Negative	0.4 +/- 0.6	
218	Second	Ceiling	Bedroom 13	Ceiling	Plaster	POOR	White		10	Positive	2.3 +/- 0.9	
219	Second	A	Bedroom 13	Wall	Plaster	FAIR	White		10	Positive	3.5 +/- 2.1	
220	Second	B	Bedroom 13	Wall	Plaster	FAIR	White		10	Positive	4.2 +/- 2.7	
221	Second	C	Bedroom 13	Wall	Plaster	POOR	White		10	Positive	3.1 +/- 2.1	

ETC - Environmental Services WILCO Environmental

APPENDIX A

All Paint Samples Taken - In Order Sampled

Please note: Post 1978 Construction, factory finished and unpainted items were not sampled

Client		Genesee County Land Bank										
Survey Location:		2448 Thomas St., Flint, MI 48504										
Survey Date:		08/01/11										
Inspectors:		Michael Gravlin			License #	P-00313			Job#	137854		
Sample #	Floor	Wall / Side	Room and #	Component	Substrate	Visual Condition	Color	Note	Depth Index	Result	mg/cm ² +/- Precision	
222	Second	D	Bedroom 13	Wall	Plaster	FAIR	White		10	Positive	4.5 +/- 2.8	
223	Second	B	Bedroom 13	Clos. Wall	Plaster	POOR	White		2.78	Positive	2.9 +/- 1.7	
224	Second	B	Bedroom 13	Clos. Ceiling	Plaster	POOR	White		2.7	Positive	3.3 +/- 1.9	
225	Second	B	Bedroom 13	Clos. Baseboard	Wood	POOR	White		3.41	Negative	0.4 +/- 0.4	
226	Second	B	Bedroom 13	Clos. Shelf	Wood	FAIR	White		2.13	Negative	0.02 +/- 0.09	
227	Second	B	Bedroom 13	Shelf Bracket	Wood	FAIR	White		3.84	Negative	0.8 +/- 0.2	
228	Second	B	Bedroom 13	Clos. Jamb	Wood	POOR	White		2.91	Negative	0.6 +/- 0.2	
229	Second	B	Bedroom 13	Clos. Stop	Wood	FAIR	White		4.53	Negative	0.6 +/- 0.4	
230	Second	B	Bedroom 13	Clos. Door	Wood	FAIR	White		7.63	Negative	0.7 +/- 0.2	
231	Second	C	Bedroom 13	Baseboard	Wood	FAIR	White		5.68	Negative	0.5 +/- 0.2	
232	Second	C	Bedroom 13	Win. Apron	Wood	FAIR	White		3.28	Negative	0.27 +/- 0.1	
233	Second	C	Bedroom 13	Win. Sill/Stool	Wood	POOR	White		9.43	Positive	1.6 +/- 0.6	
234	Second	C	Bedroom 13	Win. Casing	Wood	FAIR	White		6.18	Positive	1.5 +/- 0.5	
235	Second	C	Bedroom 13	Win. Stop	Wood	FAIR	White		4.18	Negative	0.6 +/- 0.2	
236	Second	D	Bedroom 13	Door Casing	Wood	FAIR	White		9.13	Positive	1.2 +/- 0.2	
237	Second	D	Bedroom 13	Door Jamb	Wood	POOR	White		10	Positive	1.9 +/- 0.8	
238	Second	D	Bedroom 13	Door Stop	Wood	POOR	White		10	Positive	2.1 +/- 0.8	
239	Second	D	Bedroom 13	Door	Wood	POOR	White		10	Positive	1.7 +/- 0.6	
240	Second	C	Bedroom 13	Wall Register	Metal	FAIR	White		10	Positive	2.7 +/- 1.1	
241	Second	A	Bedroom 14	Wall Register	Metal	FAIR	White		10	Positive	1.1 +/- 0.2	
242	Second	A	Bedroom 14	Wall	Plaster	FAIR	White		10	Negative	0.8 +/- 0.2	
243	Second	B	Bedroom 14	Wall	Plaster	FAIR	White		10	Negative	0.6 +/- 0.4	
244	Second	C	Bedroom 14	Wall	Plaster	FAIR	White		4.56	Negative	0.09 +/- 0.09	
245	Second	D	Bedroom 14	Wall	Plaster	FAIR	White		7.86	Negative	0.15 +/- 0.13	
246	Second	Ceiling	Bedroom 14	Ceiling	Plaster	FAIR	White		10	Negative	0.5 +/- 0.5	
247	Second	D	Bedroom 14	Clos. Wall	Plaster	FAIR	White		5.85	Negative	0.27 +/- 0.08	
248	Second	D	Bedroom 14	Clos. Ceiling	Plaster	FAIR	White		6.14	Positive	1.3 +/- 0.2	
249	Second	D	Bedroom 14	Clos. Shelf	Wood	FAIR	White		1	Negative	0 +/- 0.02	
250	Second	D	Bedroom 14	Clothes Rod	Wood	FAIR	White		1	Negative	0 +/- 0.03	
251	Second	D	Bedroom 14	Shelf Bracket	Wood	FAIR	White		7.91	Negative	0.7 +/- 0.2	
252	Second	D	Bedroom 14	Clos. Baseboard	Wood	FAIR	White		4.04	Negative	0.5 +/- 0.4	
253	Second	D	Bedroom 14	Clos. Stop	Wood	FAIR	White		4.88	Negative	0.5 +/- 0.4	
254	Second	D	Bedroom 14	Clos. Jamb	Wood	FAIR	White		1.98	Negative	0.19 +/- 0.3	
255	Second	D	Bedroom 14	Clos. Casing	Wood	FAIR	White		10	Positive	1 +/- 0.2	
256	Second	C	Bedroom 14	Clos. Door	Wood	FAIR	White		10	Negative	0.6 +/- 0.4	
257	Second	C	Bedroom 14	Clos. Baseboard	Wood	FAIR	White		9.35	Positive	1.3 +/- 0.3	
258	Second	C	Bedroom 14	Win. Apron	Wood	FAIR	White		10	Positive	2.4 +/- 1.3	

ETC - Environmental Services WILCO Environmental

APPENDIX A

All Paint Samples Taken - In Order Sampled

Please note: Post 1978 Construction, factory finished and unpainted items were not sampled

Client		Genesee County Land Bank									
Survey Location:		2448 Thomas St., Flint, MI 48504									
Survey Date:		08/01/11									
Inspectors:		Michael Gravlin			License #	P-00313			Job#	137854	
Sample #	Floor	Wall / Side	Room and #	Component	Substrate	Visual Condition	Color	Note	Depth Index	Result	mg/cm ² +/- Precision
259	Second	C	Bedroom 14	Win. Sill/Stool	Wood	FAIR	White		10	Positive	2.6 +/- 1.5
260	Second	C	Bedroom 14	Win. Casing	Wood	FAIR	White		10	Positive	2.3 +/- 0.8
261	Second	C	Bedroom 14	Win. Stop	Wood	FAIR	White		10	Positive	1.6 +/- 0.6
262	Second	A	Bedroom 14	Door Casing	Wood	FAIR	White		10	Negative	0.9 +/- 0.2
263	Second	A	Bedroom 14	Door Jamb	Wood	POOR	White		10	Positive	1.6 +/- 0.6
264	Second	A	Bedroom 14	Door Stop	Wood	POOR	White		10	Positive	1.7 +/- 0.7
265	Second	A	Bedroom 14	Door	Wood	POOR	White		10	Positive	2.9 +/- 1.7
266	Basement	D	Basement 8	Bas. Win. Sash, ext.	Metal	POOR	Black		1.32	Negative	0.4 +/- 0.4
267	Basement	D	Basement 8	Bas. Win. Jamb	Metal	POOR	Black		1	Negative	0.28 +/- 0.27
268	Exterior	A	Ext. House 15	Railing	Metal	POOR	Black		1.19	Negative	0.01 +/- 0.05
269	Exterior	A	Ext. House 15	Door Casing	Wood	POOR	White		3.1	Negative	0.4 +/- 0.6
270	Exterior	A	Ext. House 15	Mailbox	Metal	POOR	Black		1	Negative	0.06 +/- 0.05
271	Exterior	A	Ext. Garage 16	Door Jamb	Wood	POOR	Red		1	Negative	0 +/- 0.03
272	Exterior	A	Ext. Garage 16	Service door	Wood	POOR	Blue		1	Negative	0 +/- 0.02
273	Exterior	A	Ext. Garage 16	Service door	Wood	POOR	Red		1	Negative	0 +/- 0.03
274			CALIBRATE						1.04	Negative	0.9 +/- 0.1
275			CALIBRATE						1.04	Negative	0.9 +/- 0.1
276			CALIBRATE						2.61	Positive	1 +/- 0.1
277	First	D	Foyer 1	Win. Sash, ext.	Wood	POOR	White			Positive	Presumed +/-
278	First	D	Foyer 1	Win. Well/Trough	Wood	POOR	White			Positive	Presumed +/-
279	First	D	Foyer 1	Win. Jamb	Wood	POOR	White			Positive	Presumed +/-
280	First	B	Dining Room 4	Win. Sash, ext.	Wood	POOR	White			Positive	Presumed +/-
281	First	B	Dining Room 4	Win. Well/Trough	Wood	POOR	White			Positive	Presumed +/-
282	First	B	Dining Room 4	Win. Jamb	Wood	POOR	White			Positive	Presumed +/-

ETC - Environmental Services WILCO Environmental

APPENDIX B

Lead Paint ONLY Samples - Ordered by Room

Please note: Post 1978 Construction, factory finished and unpainted items were not sampled

Client		Genesee County Land Bank										
Survey Location:		2448 Thomas St., Flint, MI 48504										
Survey Date:		08/01/11										
Inspectors:		Michael Gravlin			License #:	P-00313			Job #:	137854		
Sample #	Floor	Wall / Side	Room and #	Component	Substrate	Visual Condition	Color	Note	Depth Index	Result	mg/cm ² +/- Precision	
38	First	Ceiling	Sun Room 2	Ceiling	Wood	FAIR	White	0	4.65	Positive	3 +/- 1.5	
39	First	A	Sun Room 2	Beam	Wood	FAIR	White	0	9.46	Positive	3.4 +/- 2.1	
40	First	A	Sun Room 2	Crown Molding	Wood	POOR	White	0	9.86	Positive	2.7 +/- 1.5	
41	First	A	Sun Room 2	Win. Mullion	Wood	FAIR	White	0	10	Positive	3.3 +/- 1.8	
42	First	A	Sun Room 2	Win. Sill/Stool	Wood	POOR	White	0	3.7	Positive	2.8 +/- 1.5	
43	First	A	Sun Room 2	Win. Jamb	Wood	POOR	White	0	10	Positive	9.7 +/- 6.2	
44	First	A	Sun Room 2	Win. Well/Trough	Wood	POOR	White	0	10	Positive	10.8 +/- 9.3	
45	First	C	Sun Room 2	Door Casing	Wood	FAIR	White	0	6.91	Positive	15.9 +/- 12.5	
46	First	C	Sun Room 2	Door Jamb	Wood	POOR	White	0	4.8	Positive	10.6 +/- 6.1	
47	First	C	Sun Room 2	Door	Wood	POOR	White	0	10	Positive	15 +/- 11.5	
49	First	C	Sun Room 2	Door Threshold	Wood	POOR	Grey	0	2.8	Positive	7 +/- 5.6	
50	First	Floor	Sun Room 2	Floor	Concrete	POOR	Grey	0	2.39	Positive	2.2 +/- 0.8	
69	First	B	Living Room 3	Win. Sash, ext.	Wood	POOR	White	0	4.62	Positive	4.7 +/- 2.8	
70	First	B	Living Room 3	Win. Well/Trough	Wood	POOR	White	0	7.53	Positive	18.3 +/- 12.9	
71	First	B	Living Room 3	Win. Jamb	Wood	POOR	White	0	5.69	Positive	19.1 +/- 13.2	
88	First	Ceiling	Mud Room 5	Soffit	Wood	POOR	Blue	0	3.92	Positive	31 +/- 18.9	
99	First	D	Kitchen 6	Win. Casing	Wood	FAIR	White	0	5.4	Positive	1.5 +/- 0.4	
101	First	D	Kitchen 6	Win. Sash	Wood	POOR	White	0	7.01	Positive	1.5 +/- 0.5	
102	First	D	Kitchen 6	Win. Sash, ext.	Wood	POOR	White	0	2.38	Positive	1.6 +/- 0.5	
103	First	D	Kitchen 6	Win. Jamb	Wood	POOR	White	0	4.02	Positive	15 +/- 11.9	
104	First	D	Kitchen 6	Win. Well/Trough	Wood	POOR	White	0	4.65	Positive	13.7 +/- 10.7	
105	First	A	Kitchen 6	Door Casing	Wood	FAIR	White	0	10	Positive	1.2 +/- 0.2	
111	First	C	Basment Stair 7	Wall	Wood	FAIR	White	0	10	Positive	2.1 +/- 0.9	
112	First	D	Basment Stair 7	Wall	Wood	FAIR	White	0	10	Positive	2 +/- 0.9	
113	First	Ceiling	Basment Stair 7	Ceiling	Plaster	POOR	White	0	10	Positive	1.4 +/- 0.4	
115	First	D	Basment Stair 7	Door Jamb	Wood	POOR	White	0	6.87	Positive	18.9 +/- 13.5	
118	First	D	Basment Stair 7	Ledge	Wood	POOR	Grey	0	5.03	Positive	1.7 +/- 0.6	
121	First	B	Basment Stair 7	Wall, Lower	Wood	POOR	White	0	6.32	Positive	1.5 +/- 0.5	
124	Exterior	B	Basment Stair 7	Stair Stringer	Wood	FAIR	Grey	0	3.26	Positive	4.6 +/- 2.8	
125	Exterior	Floor	Basment Stair 7	Stair Tread	Wood	FAIR	Grey	0	5.49	Positive	11.7 +/- 10.5	
134	Exterior	Ceiling	Basement 8	Beam	Metal	POOR	White	0	1.66	Positive	5.3 +/- 3.3	
135	Exterior	Center	Basement 8	Support Pole	Metal	POOR	White	0	2.04	Positive	5.8 +/- 3.9	
137	Exterior	A	Basement 8	Pipe/Gasline	Metal	POOR	White	0	2.1	Positive	1.2 +/- 0.2	
162	Second	Ceiling	Hallway 10	Attic cover casing	Wood	FAIR	White	0	10	Positive	1.8 +/- 0.8	
163	Second	Ceiling	Hallway 10	Attic Cover	Wood	FAIR	White	0	10	Positive	2.2 +/- 0.8	
164	Second	D	Hallway 10	Clos. Casing	Wood	POOR	White	0	10	Positive	2.4 +/- 0.9	
165	Second	D	Hallway 10	Clos. Jamb	Wood	POOR	Pink	0	4	Positive	1.5 +/- 0.4	
166	Second	D	Hallway 10	Clos. Stop	Wood	FAIR	Pink	0	2.67	Positive	2 +/- 0.9	

ETC - Environmental Services WILCO Environmental

APPENDIX B

Lead Paint ONLY Samples - Ordered by Room

Please note: Post 1978 Construction, factory finished and unpainted items were not sampled

Client		Genesee County Land Bank										
Survey Location:		2448 Thomas St., Flint, MI 48504										
Survey Date:		08/01/11										
Inspectors:		Michael Gravlin			License #:	P-00313			Job #:	137854		
Sample #	Floor	Wall / Side	Room and #	Component	Substrate	Visual Condition	Color	Note	Depth Index	Result	mg/cm ² +/- Precision	
167	Second	D	Hallway 10	Clos. Baseboard	Wood	FAIR	Pink	0	2.16	Positive	2 +/- 0.7	
168	Second	D	Hallway 10	Clos. Shelf	Wood	FAIR	White	0	3.72	Positive	1.8 +/- 0.7	
169	Second	D	Hallway 10	Shelf Bracket	Wood	FAIR	White	0	5.34	Positive	1.6 +/- 0.5	
172	Second	B	Hallway 10	Door Casing	Wood	POOR	White	0	10	Positive	1.8 +/- 0.8	
173	Second	B	Hallway 10	Door Jamb	Wood	POOR	White	0	10	Positive	2 +/- 0.7	
174	Second	C	Hallway 10	Baseboard	Wood	FAIR	White	0	9.57	Positive	1.5 +/- 0.5	
182	Second	A	Bathroom 11	Win. Apron	Wood	FAIR	White	0	10	Positive	2.5 +/- 1.3	
183	Second	A	Bathroom 11	Win. Sill/Stool	Wood	FAIR	White	0	6.23	Positive	1.7 +/- 0.7	
184	Second	A	Bathroom 11	Win. Casing	Wood	FAIR	White	0	7.01	Positive	2.4 +/- 1.3	
185	Second	A	Bathroom 11	Win. Sash	Wood	FAIR	White	0	10	Positive	1.8 +/- 0.7	
186	Second	A	Bathroom 11	Win. Sash, ext.	Wood	POOR	White	0	4.79	Positive	3.8 +/- 1.9	
187	Second	A	Bathroom 11	Win. Well/Trough	Wood	POOR	White	0	8.46	Positive	16.3 +/- 12.3	
188	Second	A	Bathroom 11	Win. Jamb	Wood	POOR	White	0	10	Positive	19.4 +/- 13.8	
189	Second	C	Bathroom 11	Door Casing	Wood	FAIR	White	0	10	Positive	1.9 +/- 0.8	
190	Second	C	Bathroom 11	Door Jamb	Wood	POOR	White	0	10	Positive	1.8 +/- 0.8	
191	Second	C	Bathroom 11	Door Stop	Wood	POOR	White	0	8.45	Positive	2.8 +/- 1.8	
192	Second	C	Bathroom 11	Door	Wood	POOR	White	0	10	Positive	1.4 +/- 0.4	
193	Second	D	Bedroom 12	Door	Wood	POOR	White	0	8.25	Positive	1.7 +/- 0.7	
194	Second	D	Bedroom 12	Door Jamb	Wood	POOR	White	0	4.37	Positive	2.6 +/- 1.4	
195	Second	D	Bedroom 12	Door Stop	Wood	POOR	White	0	10	Positive	2.1 +/- 0.8	
196	Second	D	Bedroom 12	Door Casing	Wood	POOR	White	0	7.55	Positive	2.9 +/- 1.7	
198	Second	D	Bedroom 12	Baseboard	Wood	FAIR	White	0	10	Positive	2.5 +/- 1.4	
199	Second	A	Bedroom 12	Win. Apron	Wood	FAIR	White	0	10	Positive	2.2 +/- 0.8	
200	Second	A	Bedroom 12	Win. Sill/Stool	Wood	FAIR	White	0	10	Positive	3 +/- 1.7	
201	Second	A	Bedroom 12	Win. Casing	Wood	FAIR	White	0	10	Positive	2.9 +/- 1.8	
202	Second	A	Bedroom 12	Win. Stop	Wood	POOR	White	0	8.71	Positive	3 +/- 1.9	
203	Second	B	Bedroom 12	Clos. Door	Wood	POOR	White	0	10	Positive	1.9 +/- 0.7	
204	Second	B	Bedroom 12	Clos. Casing	Wood	FAIR	White	0	10	Positive	2.8 +/- 1.7	
205	Second	B	Bedroom 12	Clos. Jamb	Wood	POOR	White	0	5.5	Positive	3.3 +/- 2.2	
206	Second	B	Bedroom 12	Clos. Stop	Wood	POOR	White	0	6.2	Positive	2.5 +/- 1.4	
207	Second	B	Bedroom 12	Clos. Baseboard	Wood	POOR	White	0	8.44	Positive	1.9 +/- 0.8	
218	Second	Ceiling	Bedroom 13	Ceiling	Plaster	POOR	White	0	10	Positive	2.3 +/- 0.9	
219	Second	A	Bedroom 13	Wall	Plaster	FAIR	White	0	10	Positive	3.5 +/- 2.1	
220	Second	B	Bedroom 13	Wall	Plaster	FAIR	White	0	10	Positive	4.2 +/- 2.7	
221	Second	C	Bedroom 13	Wall	Plaster	POOR	White	0	10	Positive	3.1 +/- 2.1	
222	Second	D	Bedroom 13	Wall	Plaster	FAIR	White	0	10	Positive	4.5 +/- 2.8	
223	Second	B	Bedroom 13	Clos. Wall	Plaster	POOR	White	0	2.78	Positive	2.9 +/- 1.7	
224	Second	B	Bedroom 13	Clos. Ceiling	Plaster	POOR	White	0	2.7	Positive	3.3 +/- 1.9	
233	Second	C	Bedroom 13	Win. Sill/Stool	Wood	POOR	White	0	9.43	Positive	1.6 +/- 0.6	

ETC - Environmental Services WILCO Environmental

APPENDIX B

Lead Paint ONLY Samples - Ordered by Room

Please note: Post 1978 Construction, factory finished and unpainted items were not sampled

Client		Genesee County Land Bank									
Survey Location:		2448 Thomas St., Flint, MI 48504									
Survey Date:		08/01/11									
Inspectors:		Michael Gravlin			License #:	P-00313			Job #:	137854	
Sample #	Floor	Wall / Side	Room and #	Component	Substrate	Visual Condition	Color	Note	Depth Index	Result	mg/cm ² +/- Precision
234	Second	C	Bedroom 13	Win. Casing	Wood	FAIR	White	0	6.18	Positive	1.5 +/- 0.5
236	Second	D	Bedroom 13	Door Casing	Wood	FAIR	White	0	9.13	Positive	1.2 +/- 0.2
237	Second	D	Bedroom 13	Door Jamb	Wood	POOR	White	0	10	Positive	1.9 +/- 0.8
238	Second	D	Bedroom 13	Door Stop	Wood	POOR	White	0	10	Positive	2.1 +/- 0.8
239	Second	D	Bedroom 13	Door	Wood	POOR	White	0	10	Positive	1.7 +/- 0.6
240	Second	C	Bedroom 13	Wall Register	Metal	FAIR	White	0	10	Positive	2.7 +/- 1.1
241	Second	A	Bedroom 14	Wall Register	Metal	FAIR	White	0	10	Positive	1.1 +/- 0.2
248	Second	D	Bedroom 14	Clos. Ceiling	Plaster	FAIR	White	0	6.14	Positive	1.3 +/- 0.2
255	Second	D	Bedroom 14	Clos. Casing	Wood	FAIR	White	0	10	Positive	1 +/- 0.2
257	Second	C	Bedroom 14	Clos. Baseboard	Wood	FAIR	White	0	9.35	Positive	1.3 +/- 0.3
258	Second	C	Bedroom 14	Win. Apron	Wood	FAIR	White	0	10	Positive	2.4 +/- 1.3
259	Second	C	Bedroom 14	Win. Sill/Stool	Wood	FAIR	White	0	10	Positive	2.6 +/- 1.5
260	Second	C	Bedroom 14	Win. Casing	Wood	FAIR	White	0	10	Positive	2.3 +/- 0.8
261	Second	C	Bedroom 14	Win. Stop	Wood	FAIR	White	0	10	Positive	1.6 +/- 0.6
263	Second	A	Bedroom 14	Door Jamb	Wood	POOR	White	0	10	Positive	1.6 +/- 0.6
264	Second	A	Bedroom 14	Door Stop	Wood	POOR	White	0	10	Positive	1.7 +/- 0.7
265	Second	A	Bedroom 14	Door	Wood	POOR	White	0	10	Positive	2.9 +/- 1.7
277	First	D	Foyer 1	Win. Sash, ext.	Wood	POOR	White	0		Positive	Presumed +/-
278	First	D	Foyer 1	Win. Well/Trough	Wood	POOR	White	0		Positive	Presumed +/-
279	First	D	Foyer 1	Win. Jamb	Wood	POOR	White	0		Positive	Presumed +/-
280	First	B	Dining Room 4	Win. Sash, ext.	Wood	POOR	White	0		Positive	Presumed +/-
281	First	B	Dining Room 4	Win. Well/Trough	Wood	POOR	White	0		Positive	Presumed +/-
282	First	B	Dining Room 4	Win. Jamb	Wood	POOR	White	0		Positive	Presumed +/-

ETC - Environmental Services WILCO Environmental

APPENDIX C

Potential Future Lead Paint Hazards - Ordered by Room

Please note: Post 1978 Construction, factory finished and unpainted items were not sampled

Client		Genesee County Land Bank										
Survey Location:		2448 Thomas St., Flint, MI 48504										
Survey Date:		08/01/11										
Inspectors:		Michael Gravlin			License #:	P-00313			Job #:	137854		
Sample #	Floor	Wall / Side	Room and #	Component	Substrate	Visual Condition	Color	Note	Depth Index	Result	mg/cm ² +/- Precision	
38	First	Ceiling	Sun Room 2	Ceiling	Wood	FAIR	White	0	4.65	Positive	3 +/- 1.5	
39	First	A	Sun Room 2	Beam	Wood	FAIR	White	0	9.46	Positive	3.4 +/- 2.1	
41	First	A	Sun Room 2	Win. Mullion	Wood	FAIR	White	0	10	Positive	3.3 +/- 1.8	
45	First	C	Sun Room 2	Door Casing	Wood	FAIR	White	0	6.91	Positive	15.9 +/- 12.5	
99	First	D	Kitchen 6	Win. Casing	Wood	FAIR	White	0	5.4	Positive	1.5 +/- 0.4	
105	First	A	Kitchen 6	Door Casing	Wood	FAIR	White	0	10	Positive	1.2 +/- 0.2	
111	First	C	Basment Stair 7	Wall	Wood	FAIR	White	0	10	Positive	2.1 +/- 0.9	
112	First	D	Basment Stair 7	Wall	Wood	FAIR	White	0	10	Positive	2 +/- 0.9	
124	Exterior	B	Basment Stair 7	Stair Stringer	Wood	FAIR	Grey	0	3.26	Positive	4.6 +/- 2.8	
125	Exterior	Floor	Basment Stair 7	Stair Tread	Wood	FAIR	Grey	0	5.49	Positive	11.7 +/- 10.5	
162	Second	Ceiling	Hallway 10	Attic cover casing	Wood	FAIR	White	0	10	Positive	1.8 +/- 0.8	
163	Second	Ceiling	Hallway 10	Attic Cover	Wood	FAIR	White	0	10	Positive	2.2 +/- 0.8	
166	Second	D	Hallway 10	Clos. Stop	Wood	FAIR	Pink	0	2.67	Positive	2 +/- 0.9	
167	Second	D	Hallway 10	Clos. Baseboard	Wood	FAIR	Pink	0	2.16	Positive	2 +/- 0.7	
168	Second	D	Hallway 10	Clos. Shelf	Wood	FAIR	White	0	3.72	Positive	1.8 +/- 0.7	
169	Second	D	Hallway 10	Shelf Bracket	Wood	FAIR	White	0	5.34	Positive	1.6 +/- 0.5	
174	Second	C	Hallway 10	Baseboard	Wood	FAIR	White	0	9.57	Positive	1.5 +/- 0.5	
182	Second	A	Bathroom 11	Win. Apron	Wood	FAIR	White	0	10	Positive	2.5 +/- 1.3	
183	Second	A	Bathroom 11	Win. Sill/Stool	Wood	FAIR	White	0	6.23	Positive	1.7 +/- 0.7	
184	Second	A	Bathroom 11	Win. Casing	Wood	FAIR	White	0	7.01	Positive	2.4 +/- 1.3	
185	Second	A	Bathroom 11	Win. Sash	Wood	FAIR	White	0	10	Positive	1.8 +/- 0.7	
189	Second	C	Bathroom 11	Door Casing	Wood	FAIR	White	0	10	Positive	1.9 +/- 0.8	
198	Second	D	Bedroom 12	Baseboard	Wood	FAIR	White	0	10	Positive	2.5 +/- 1.4	
199	Second	A	Bedroom 12	Win. Apron	Wood	FAIR	White	0	10	Positive	2.2 +/- 0.8	
200	Second	A	Bedroom 12	Win. Sill/Stool	Wood	FAIR	White	0	10	Positive	3 +/- 1.7	
201	Second	A	Bedroom 12	Win. Casing	Wood	FAIR	White	0	10	Positive	2.9 +/- 1.8	
204	Second	B	Bedroom 12	Clos. Casing	Wood	FAIR	White	0	10	Positive	2.8 +/- 1.7	
219	Second	A	Bedroom 13	Wall	Plaster	FAIR	White	0	10	Positive	3.5 +/- 2.1	
220	Second	B	Bedroom 13	Wall	Plaster	FAIR	White	0	10	Positive	4.2 +/- 2.7	
222	Second	D	Bedroom 13	Wall	Plaster	FAIR	White	0	10	Positive	4.5 +/- 2.8	
234	Second	C	Bedroom 13	Win. Casing	Wood	FAIR	White	0	6.18	Positive	1.5 +/- 0.5	
236	Second	D	Bedroom 13	Door Casing	Wood	FAIR	White	0	9.13	Positive	1.2 +/- 0.2	
240	Second	C	Bedroom 13	Wall Register	Metal	FAIR	White	0	10	Positive	2.7 +/- 1.1	
241	Second	A	Bedroom 14	Wall Register	Metal	FAIR	White	0	10	Positive	1.1 +/- 0.2	

ETC - Environmental Services WILCO Environmental

APPENDIX C

Potential Future Lead Paint Hazards - Ordered by Room

Please note: Post 1978 Construction, factory finished and unpainted items were not sampled

Client		Genesee County Land Bank										
Survey Location:		2448 Thomas St., Flint, MI 48504										
Survey Date:		08/01/11										
Inspectors:		Michael Gravlin			License #:	P-00313			Job #:	137854		
Sample #	Floor	Wall / Side	Room and #	Component	Substrate	Visual Condition	Color	Note	Depth Index	Result	mg/cm^2 +/- Precision	
248	Second	D	Bedroom 14	Clos. Ceiling	Plaster	FAIR	White	0	6.14	Positive	1.3 +/- 0.2	
255	Second	D	Bedroom 14	Clos. Casing	Wood	FAIR	White	0	10	Positive	1 +/- 0.2	
257	Second	C	Bedroom 14	Clos. Baseboard	Wood	FAIR	White	0	9.35	Positive	1.3 +/- 0.3	
258	Second	C	Bedroom 14	Win. Apron	Wood	FAIR	White	0	10	Positive	2.4 +/- 1.3	
259	Second	C	Bedroom 14	Win. Sill/Stool	Wood	FAIR	White	0	10	Positive	2.6 +/- 1.5	
260	Second	C	Bedroom 14	Win. Casing	Wood	FAIR	White	0	10	Positive	2.3 +/- 0.8	
261	Second	C	Bedroom 14	Win. Stop	Wood	FAIR	White	0	10	Positive	1.6 +/- 0.6	

APPENDIX D

Maps of Residence

The inspection process uses a standard method of describing where lead paint is located. This is so that all parties involved will have a clear understanding as to what surfaces contain lead.

The outsides of the house will be lettered, starting with the letter A for the side of the house where the house gets its street address from. Starting at the A side, the rest of the house is lettered consecutively, clockwise around the house. Regardless of where the front door is located, the side of the house facing the street where the address is derived from will always be side A.

Inside the house, the process is much the same. The wall of each room that is nearest the A side of the house will be identified as wall A in the report. The wall nearest the B side will be labeled wall B, and so on.

For identifying the rooms and other areas of the interior of the house, a numbering system is used. Most rooms, with the exception of the kitchen and bath could be used for different purposes. When numbers are used, deciphering which room is called what will not be required. See dwelling map and labeling to determine the locations of the tests and hazards.

EXAMPLE

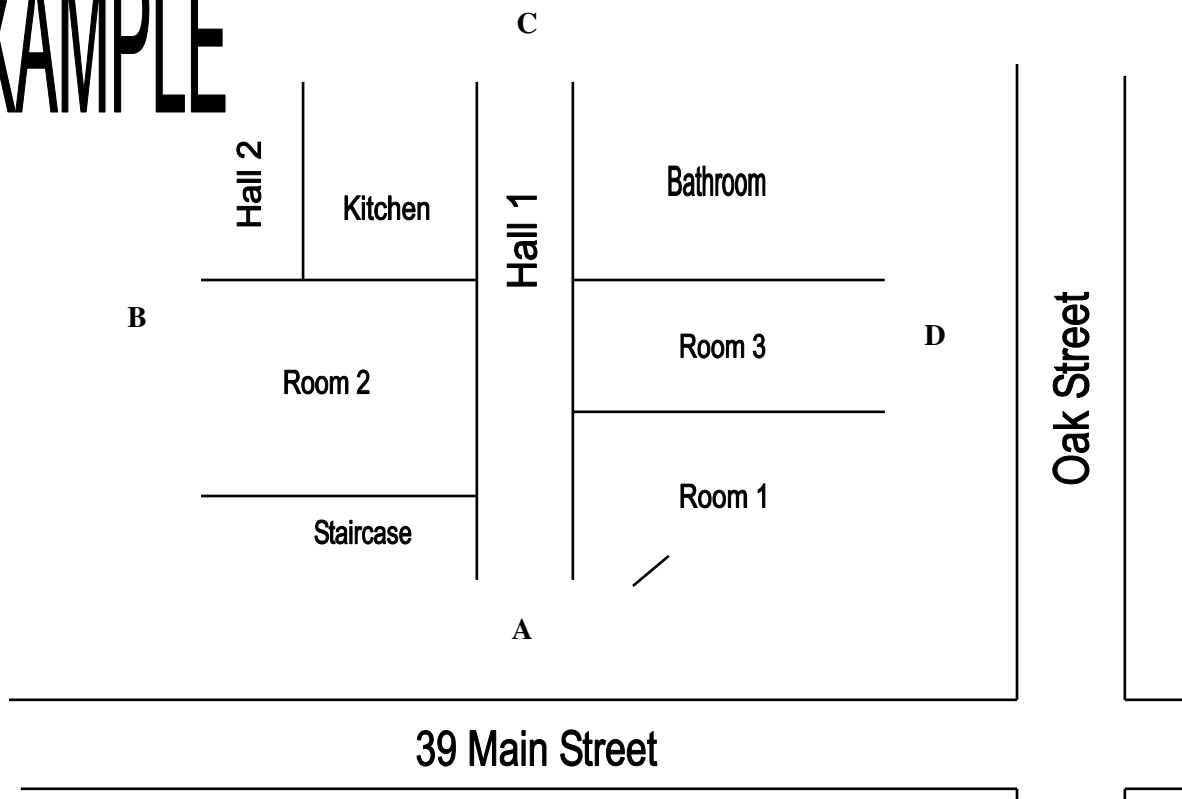

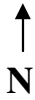

Side C
1st Floor

2448 Thomas
Flint, MI 48504
Year Built: 1940's

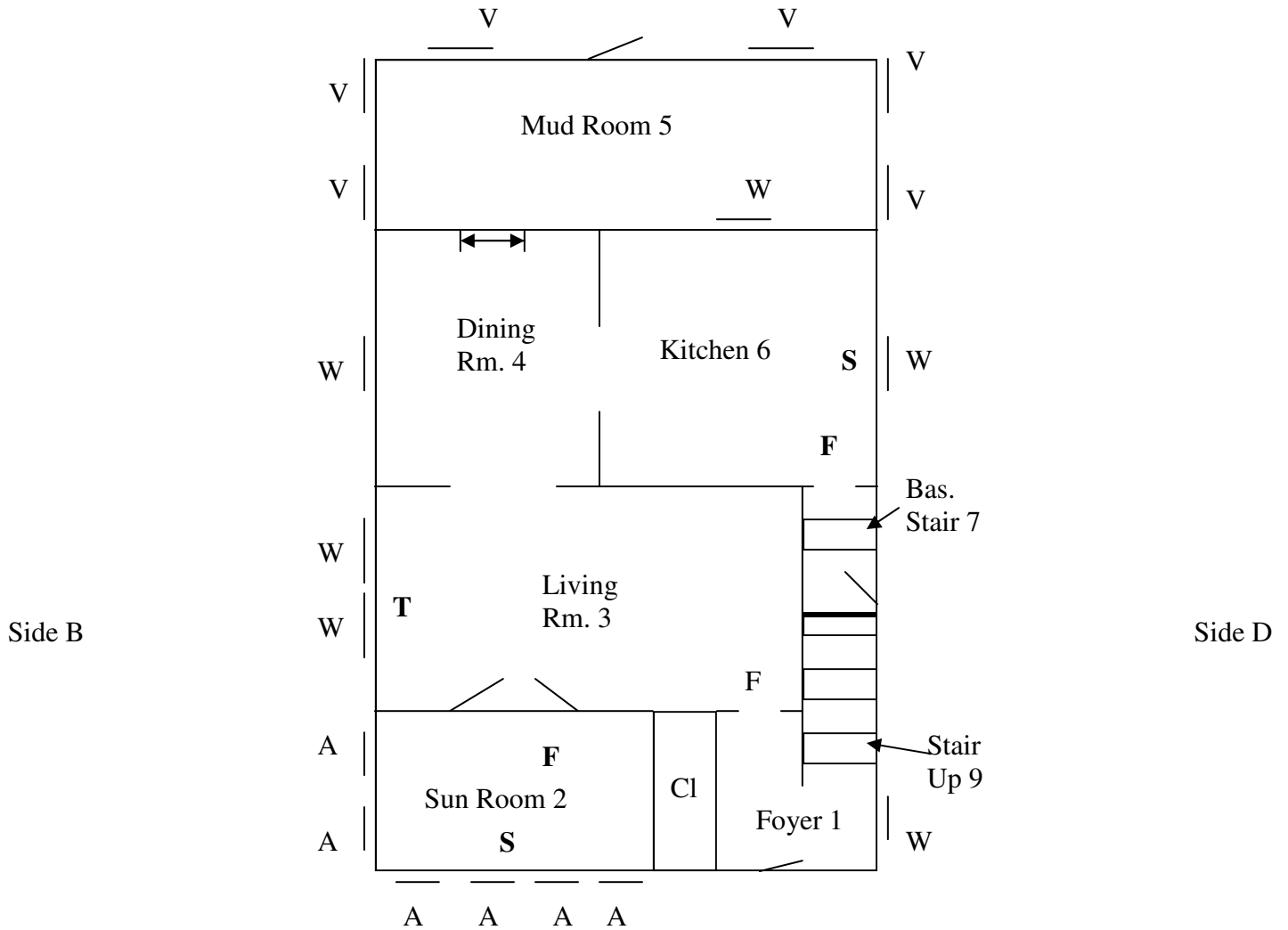

- F = Floor Dust Wipe Sample
- S = Windowsill Dust Wipe Sample
- T = Window Trough Dust Wipe Sample
- W = Wood windows
- V = Vinyl windows
- A = Aluminum windows
- M = Metal windows
- GB = Glass block windows

Please Note: This is a rough floor plan only. All items, (doorways, Windows, etc.) may not be included in this illustration. Also, room and component sizes are not drawn to scale.

Side A

Genesee County Land Bank
137854

2448 Thomas
 Flint, MI 48504
 Year Built: 1940's

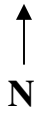

Side C

Basement Level

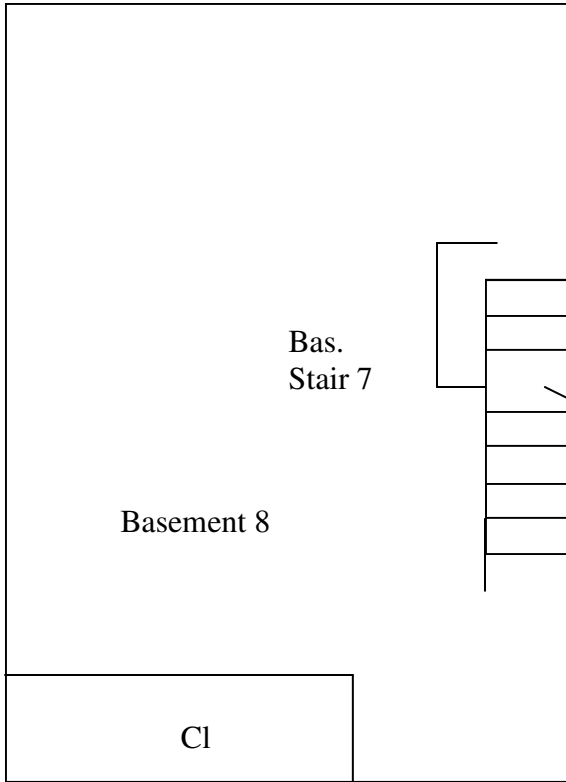

2nd Floor

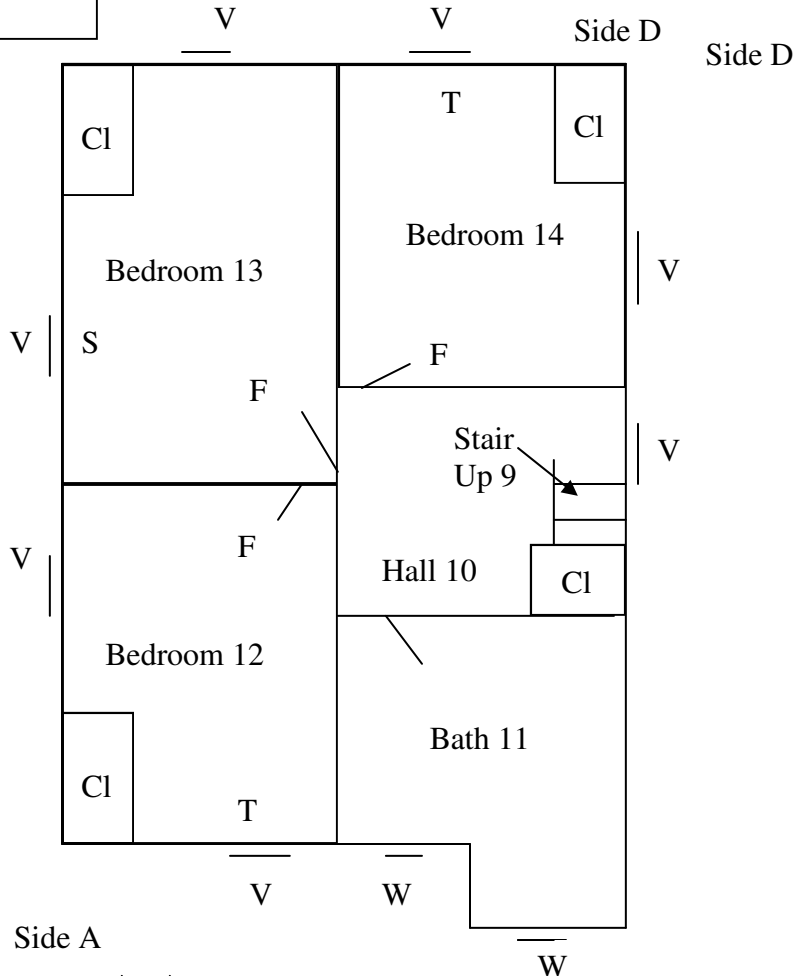

F = Floor Dust Wipe Sample

S = Windowsill Dust Wipe Sample

T = Window Trough Dust Wipe Sample

Please Note: This is a rough floor plan only. All items, (doorways, windows, etc.) may not be included in this illustration. Also, room and component sizes are not drawn to scale.

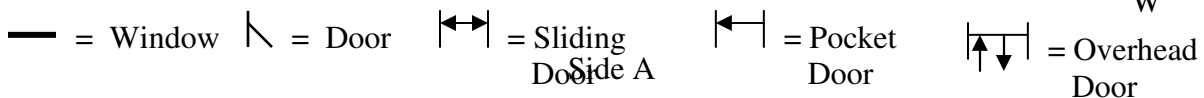

Genesee County



Side C
Site Layout

2448 Thomas
Flint, MI 48504
Year Built: 1940's

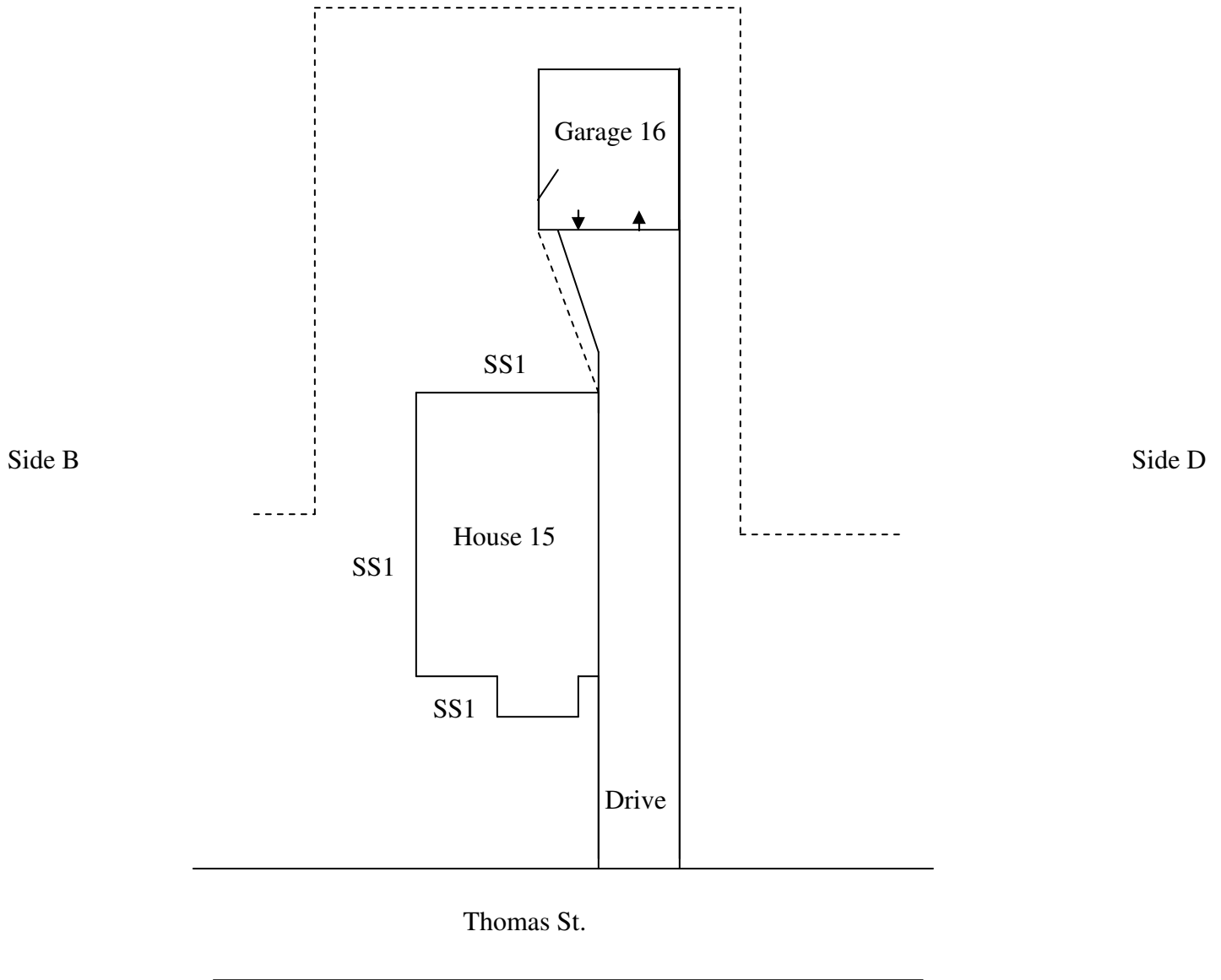

SS = Soil Sample

Please Note: This is a rough floor plan only. All items, (doorways, Windows, etc.) may not be included in this illustration. Also, room and component sizes are not drawn to scale.

Side A

Genesee County Land Bank
137854

APPENDIX E

Resident Questionnaire and Building Condition Form

RESIDENT QUESTIONNAIRE

This residence was VACANT at the time of the inspection

Do any children under the age of 18 live in the home?	N/A—Vacant
What are the ages of the children?	N/A—Vacant
Do any children under the age of 18 visit regularly in the home?	N/A—Vacant
What are the ages of the children?	N/A—Vacant
Any known elevated blood lead levels?	N/A—Vacant
Location of children (under 7) bedrooms.	N/A—Vacant
Where do children eat? Rm. #'s:	N/A—Vacant
What room are toys stored (children play)?	N/A—Vacant
Where do children play outdoors?	N/A—Vacant
Which windows are opened most often?	N/A—Vacant
Rooms with window air conditioners.	None
Have any renovation work items been completed in the last several years?	Unknown
Are you planning any renovations of the home?	Yes—gut/rehab in summer of 2011
Are you planning any landscaping activities?	Unknown
Is there evidence of chewed, chipped, or peeling paints?	Yes—See XRF results
Have any previous lead inspections/assessments been completed at this property?	Unknown
Have any lead hazard control activities been conducted at this address?	Unknown
Are you aware of any current lead paint hazards in this home?	No
Has a housing code violation ever been issued for this building?	Unknown
Which entrances are used most often?	N/A—Vacant
Do you have a vegetable garden?	N/A—Vacant
Is there a dog or cat in the home?	N/A—Vacant
How often is the house regularly cleaned?	N/A—Vacant
How often is the house thoroughly cleaned?	N/A—Vacant
What cleaning methods are used?	N/A—Vacant
Do any household members work in a field that might expose them to lead?	N/A—Vacant
If yes to 21, where are work clothes stored for cleaning?	N/A—Vacant
Who was interviewed for this section?	Visual observation by the Technician

Building Condition Form

If two or more components have been found to be in poor condition, this house needs more than a Risk Assessment. A complete paint inspection will give information as to potential hazards not identified in a standard Risk Assessment.

Condition	Yes	No
Roof missing parts of surface covering?		X
Roof has holes or large cracks?		X
Gutters or downspouts broken?		X
Chimney or masonry cracked, with loose or missing components, out of plumb or otherwise deteriorated?		X
Exterior or interior walls have large cracks, or damage requiring more than routine painting?		X
Exterior siding missing components?		X
Water stains on interior walls or ceilings?		X
Plaster walls deteriorated?		X
Two or more windows or doors missing, broken or boarded up?		X
Porch or steps have major cracks, missing materials, structural leans, or visibly unsound?		X
Foundation has damage, structural problems, leans or is unsound?		X
Are there any debris piles or other "extreme" storage issues around the yard/grounds?		X
Other conditions not listed		X
Total	0	13

APPENDIX F

Re-Evaluation Schedule Chart

**Standard Reevaluation Schedule
(See Notes to Table)**

Schedule	Evaluation Results	Action Taken	Reevaluation Frequency	Visual Survey (by owner or owner's representative)
1	Combination risk assessment/inspection finds no leaded dust or soil and no lead-based paint	None	None	None
2	No lead-based paint hazards found during risk assessment conducted before hazard control or at clearance (hazards include dust and soil).	None	3 years	Annually and whenever information indicates a possible problem
3	The average of leaded dust levels on all floors, interior window sills, or window troughs sampled exceeds the applicable standard, but by less than a factor of 10.	A. Interim controls and/or hazard abatement (or mixture of the two), including, but not necessarily limited to, dust removal. This schedule does not include window replacement.	1 year, 2 years	Same as Schedule 2, except for encapsulants. The first visual survey of encapsulants should be done one month after clearance; the second should be done six months later and annually thereafter.
		B. Treatments specified in section A plus replacement of all windows with lead hazards	1 year	
		C. Abatement of all lead-based paint using encapsulation or enclosure	None	Same as Schedule 3 above
		D. Removal of all lead-based paint	None	None
4	The average of leaded dust levels on all floors, interiors window sills, or window troughs sampled exceeds the applicable standard by a factor of 10 or more	A. Interim controls and/or hazard abatement (or mixture of the two), including, but not necessarily limited to, dust removal. This schedule does not include window replacement.	6 months, 1 year, 2 years	Same as Schedule 3
		B. Treatments specified in section A plus replacement of all windows with lead hazards	6 months 2 years	Same as Schedule 3
		C. Abatement of all lead-based paint using encapsulation or enclosure	None	Same as Schedule 3
		D. Removal of all lead-based paint	None	None
5	No leaded dust or leaded soil hazards identified, but lead-based paint or lead-based paint hazards are found.	A. Interim controls or mixture of interim controls and abatement (not including window replacement)	2 years	Same as Schedule 3
		B. Mixture of interim controls and abatement, including window replacement	3 years	Same as Schedule 3
		C. Abatement of all lead-based paint hazards, but not all lead-based paint	4 years	Same as Schedule 3
		D. Abatement of all lead-based paint using encapsulation or enclosure	None	Same as Schedule 3
		E. Removal of all lead-based paint	None	
6	Bare leaded soil exceeds standard, but less than 5.000 μ g/g.	Interim controls	None	3 months to check new ground cover, then annually to identify new bare spots
7	Bare leaded soil greater than or equal to 5.000 μ g/g.	Abatement (paving or removal)	None	None for removal, annually to identify new bare spots or deterioration of paving

Standard Reevaluation Schedule (continued)

Notes to Table:

When more than one schedule applies to a dwelling, use the one with the most stringent reevaluation schedule. Do not use the results of a reevaluation for Schedule 2.

A lead-based paint hazard includes deteriorated lead-based paint and leaded dust and soil above applicable standards.

The frequency of reevaluations and the interval between reevaluations depends on the findings at each reevaluation and the action taken. For example, a dwelling unit or common area falling under Schedule 3.A would be reevaluated one year after clearance. If no lead-based paint hazards are detected at that time, the unit or area would be reevaluated again two years after the first reevaluation. If no hazards are found in the second reevaluation, no further reevaluation is necessary, but annual visual monitoring should continue.

If, on the other hand, the unit or common area fails a reevaluation, a new reevaluation schedule should be determined based on the results of the reevaluation and the action taken. For instance, if the reevaluation finds deteriorated lead-based paint but no lead-contaminated dust, and the action taken is paint stabilization, Schedule 5.A would apply, which indicates that the next reevaluation should be in two years. If, however, the owner of this same property decides to abate all lead-based paint hazards instead of doing only paint stabilization, the property would move to Schedule 5.C, which calls for reevaluation four years from the date of clearance after the hazard abatement.

Following another scenario, suppose a reevaluation of this same dwelling unit or common area finds that the average dust lead levels on sampled window troughs exceeds the applicable standard by a factor of 10 or more, but no other lead-based paint hazards. The owner conducts dust removal. In this case the next reevaluation would be six months after clearance.

The initial evaluation results determine which reevaluation schedule should be applied. An initial evaluation can be a risk assessment, a risk assessment/ inspection combination, or, if the owner has opted to bypass the initial evaluation and proceed directly to controlling suspected hazards, a combination risk assessment/clearance examination. This type of clearance must be conducted by a certified risk assessor, who should determine if all hazards were in fact controlled. The results of the initial clearance dust tests, soil sampling and visual examination should be used to determine the appropriate schedule. If repeated cleaning was necessary to achieve clearance, use the results of the dust tests before repeated cleaning was performed for schedule determination.

If a unit fails two consecutive reevaluations, the reevaluation interval should be reduced by half and the number of reevaluations should be doubled. If deteriorated lead-based paint hazards continue to occur, then the offending components/surfaces should be abated. If dwellings with dust hazards but no paint-related hazards repeatedly fail reevaluations, the exterior source should be identified (if identification efforts fail, regular dust removal efforts are needed).

APPENDIX G

Site Photos



Front of Home (Side A)



Side B



Rear of Home (Side C)



Side D



Garage Side A



Room 2 door



Room 2—window sill, trough



Room 5 soffit

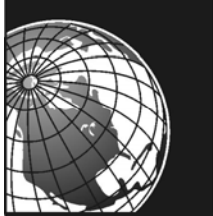

GLOBAL
ENVIRONMENTAL
ENGINEERING INC.

**Rehabilitation
Environmental Inspection Report
For:
40-11-382-024
2448 Thomas Street
Flint, Michigan 48504**

NSP-2 July 2011
Global Project No. F1438E

Prepared by:

GLOBAL ENVIRONMENTAL ENGINEERING INC.
6140 Rashelle Drive, Suite 1
Flint, Michigan 48507
(810) 238-9190
Fax: (810) 238-9195

Prepared for:

Genesee County Land Bank
452 S. Saginaw Street – 2nd Floor
Flint, Michigan 48502

Site Summary

HM	A

Genesee County Rehabilitation Environmental Inspection Summary

40-11-382-024
2448 Thomas Street
Flint, Michigan 48504



Year Built:	1928	Square Footage:	956
Latitude:	N 43° 01'01.47"	Longitude:	W 83° 43'31.36"
Gas:	Unknown	Electric:	Unknown

Comments: A two story wood framed residential structure with vinyl siding and a basement.

Inspected By:

Julie Herrick
Robert Dunlap
Desiree Bable

Inspected On:

July 18, 2011

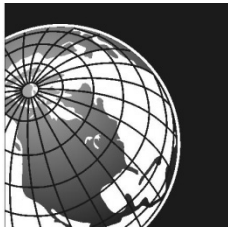

GLOBAL
ENVIRONMENTAL
ENGINEERING INC.

Table of Contents

1.0	INTRODUCTION.....	1
2.0	HAZARDOUS MATERIALS INSPECTION	1
3.0	ASBESTOS CONTAINING BUILDING MATERIAL INSPECTION	1
3.1	Asbestos Inspection	1
3.2	Sample Collection	1
3.3	Laboratory Analysis/Results.....	2
3.4	Category I Non-Friable ACM	2
4.0	SIGNATURE	3

Tables and Attachments

Table 1	Hazardous Material List
Table 2	Suspect Asbestos Containing Materials
Table 3	Category I Non-Friable
Attachment 1	Site Inspection Photos
Attachment 2	Floor Plan with Sample Locations
Attachment 3	Asbestos Laboratory Analytical Results
Attachment 4	MDEQ "Notice of Intent to Demolish" Form

Site Summary Legend for Report Cover

A = Friable Asbestos Containing Materials
HM = Hazardous Materials
O = Occupied
ED = Emergency Demolition
T = Tire

1.0 INTRODUCTION

The Genesee County Land Bank retained Global Environmental Engineering Inc. (Global) to complete a pre-renovation environmental inspection for the following property:

Property:

- 2448 Thomas Street, Flint, Michigan 48504
- Parcel No: 40-11-382-024

Description:

The building is a two-story, wood framed, vinyl sided residential structure with a basement and garage.

2.0 HAZARDOUS MATERIALS INSPECTION

The property was inspected for the presence of household hazardous materials, including but not limited to; paint, solvents, pesticides/fertilizers, fuel, oil, fluorescent light fixture ballasts, fluorescent light bulbs, underground storage tanks (USTs), above ground storage tanks (ASTs), and mercury thermostats. The Global inspectors documented the location of each of the hazardous materials identified and marked the materials with spray paint. At the discretion of the inspectors photographs were also obtained during the inspection of potential and known hazardous materials. Hazardous materials identified are listed on **Table 1**. If obtained, photographs of hazardous materials for the above referenced property are included in **Attachment 1**.

3.0 ASBESTOS CONTAINING BUILDING MATERIAL INSPECTION

The property was inspected for the presence of asbestos-containing materials (ACMs) in order to meet the requirements of 40 CFR, Part 61, Subpart M, National Emissions Standards for Hazardous Air Pollutants (NESHAP).

3.1 Asbestos Inspection

The property was inspected for the presence of suspected ACMs. Typical building materials that may contain asbestos include drywall, floor tiles, roofing felt and shingles, ceiling tiles, insulation, pipe insulation, and duct insulation. Friable materials are defined as materials that when dry may be crumbled or reduced to powder using hand pressure and thus release asbestos fibers.

For the purpose of this inspection non-friable materials that may become friable during the renovation/demolition (Category II non-friable) were identified and sampled.

3.2 Sample Collection

At least one sample of each friable suspected ACM identified during the inspection was collected. A Michigan Accredited Asbestos Inspector collected representative samples of each friable suspected ACM. Each sample was placed into a sealed plastic bag and labeled. A description of the material and location of the sample collected was recorded in the field notes. The total quantity of each suspected ACM was estimated and recorded in the field notes.

A listing of suspect ACMs at this property that were sampled and sent to the laboratory for analysis is included in **Table 2**. A copy of a floor plan showing sample locations is included in **Attachment 2**.

3.3 Laboratory Analysis/Results

Each sample of suspect ACM collected at this property was analyzed for asbestos content using polarized light microscopy (PLM) by a NVLAP and NIST accredited laboratory in accordance with 40 CFR Ch. I (1-1-87 Edition) Part 763, Subpart F, Appendix A, pp. 293-299. Asbestos containing materials are defined as materials that contain greater than one percent (>1%) asbestos.

Each sample collected for analysis was delivered via UPS to International Asbestos Testing Laboratories (IATL) 9000 Commerce Parkway, Suite B, Mt. Laurel, New Jersey. Laboratory results are included in **Attachment 3**.

The results of the laboratory analysis indicated, only one of the suspect materials sampled, the duct wrap and 2" tape (2448-4) contains asbestos. A copy of the laboratory results is included as **Attachment 3**.

The duct wrap and tape located in the register boots and runs throughout should be properly removed and disposed by a licensed asbestos abatement contractor as part of the renovation project.

A Notice of Intent to Renovate/Demolish form must be filed with the State of Michigan Department of Consumer Industry at least 10 days before beginning a renovation project or the removal of the material. A form has been included for your future use.

3.4 Category I Non-Friable ACM

Bendable, flexible, and tar based non-friable materials (Category I non-friable) were identified and sampled. For the purpose of this inspection Category I Non-Friable materials that may become friable during the renovation were identified and sampled. A copy of the MDEQ "Notice of Intent to Demolish" form is included as **Attachment 4**.

4.0 SIGNATURE

This report was prepared based on the site conditions that existed at the time of the inspection, sample collection, and the laboratory analytical results.

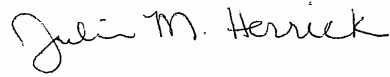

Prepared by: _____
Julie Herrick, Michigan Certified Asbestos Inspector
Michigan Accreditation Number A35947



Reviewed by: _____
Mark Keyes, Michigan Certified Asbestos Inspector
Michigan Accreditation Number A6041

Tables

**Genesee County Rehabilitation
Environmental Inspection Summary**

40-11-382-024
2448 Thomas Street
Flint, Michigan 48504

TABLE 1

HAZARDOUS MATERIALS

Material	Quantity & Units	Location
Mercury Thermostat	1 Unit(s)	Dining Room
Refrigerator	1 Unit(s)	Kitchen
Fluorescent Light Bulbs	2 - 2' Bulb(s)	Kitchen
Smoke Detector	3 Unit(s)	Living Room
Paint	7 - 1 Gallon(s)	Basement
Paint	1 - 5 Gallon(s)	Basement
Sealer	1 - 1 Quart(s)	Basement
Polyurethane	1 - 5 Gallon(s)	Garage
Brake Cleaner	1 - 1 Quart(s)	Garage
Air Conditioner	1 Unit(s)	Side of House

TIRE(s) REPORT

Material	Quantity & Units	Location
No Tires Identified		

**Genesee County Rehabilitation
Environmental Inspection Summary**

40-11-382-024
2448 Thomas Street
Flint, Michigan 48504

**TABLE 2
SUSPECT ASBESTOS CONTAINING MATERIALS**

Sample ID	Material	Sample Location	Location	Estimated Quantity	% ACM	ACM Present
2448-1a	Window Caulk	Kitchen	Windows Throughout	3 Square feet	Non Detect	No
2448-1b	Window Caulk	Living Room	Windows Throughout	Same as above	Non Detect	No
2448-1c	Window Caulk	Dining Room	Windows Throughout	Same as above	Non Detect	No
2448-2	2x4 Ceiling Tile White Perforated	Sunroom	Sunroom	288 Square feet	Non Detect	No
2448-3a	Plaster	Dining Room	Throughout	3,824 Square feet	Non Detect	No
2448-3b	Plaster	Living Room	Throughout	Same as above	Non Detect	No
2448-3c	Plaster	Bedroom	Throughout	Same as above	Non Detect	No
2448-3d	Plaster	2nd Floor Bedroom	Throughout	Same as above	Non Detect	No
2448-3e	Plaster	2nd Floor Bedroom	Throughout	Same as above	Non Detect	No
2448-4	Duct Wrap 2" Tape	Living Room Boot	Basement Duct Work	40 Linear feet	45	Yes
2448-4	Duct Wrap Insulation	Living Room Boot	Register Boots/Runs	98 Square feet	45	Yes
2448-5a	Popcorn Stucco	Living Room Ceiling	Living Room Ceiling	240 Square feet	Non Detect	No
2448-5b	Popcorn Stucco	Entryway Ceiling	Entryway Ceiling	Same as above	Non Detect	No
2448-5c	Popcorn Stucco	Living Room Ceiling	Living Room Ceiling	Same as above	Non Detect	No
2448-6	Roofing Material	2nd Floor Bedroom	House Roof	770 Square feet	Non Detect	No
2448-7	Stucco	2nd Floor Bathroom	2nd Floor Bathroom Ceiling	42 Square feet	Non Detect	No
2448-8	1x1 Ceiling Tile White Perforated	Basement Ceiling	Basement Ceiling	80 Square feet	Non Detect	No

Date Inspected: 07/18/2011

Asbestos samples analyzed by Polarized light Microscopy (PLM). ACM - Asbestos Containing Material

Asbestos containing materials are defined as materials that contain greater than one percent (>1%) asbestos.

Bolded and Shaded materials contain asbestos and Global recommends the materials be removed prior to renovation/demolition activities.

Attachment 1



Mercury Thermostat
Dining room



Refrigerator
Kitchen



Fluorescent Lights
Kitchen



Smoke Detectors
Living Room



Paints and Sealer
Basement



Polyurethane and Brake Cleaner
Garage

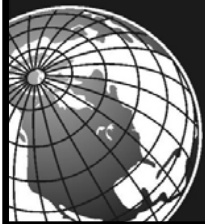

**GLOBAL
ENVIRONMENTAL
ENGINEERING INC.**

Genesee County Renovation Environmental Inspection Summary
Parcel ID: 40-11-382-024
Address: 2448 Thomas Street, Flint, Michigan

**Pictures of Hazardous
Materials**

Prepared By:	J.M.H.
Taken:	07/18/2011
Page:	1



Air Conditioner
Side of House

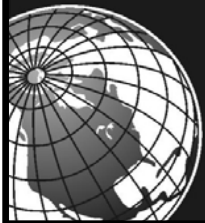

GLOBAL
ENVIRONMENTAL
ENGINEERING INC.

Genesee County Renovation Environmental Inspection Summary
Parcel ID: 40-11-382-024
Address: 2448 Thomas Street, Flint, Michigan

**Pictures of Hazardous
Materials**

Prepared By:	J.M.H.
Taken:	07/18/2011
Page:	2



Example of Duct Wrap
Basement



Example of Duct Wrap
Basement



Example of Duct Wrap
Basement

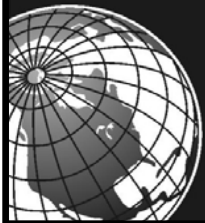

**GLOBAL
ENVIRONMENTAL
ENGINEERING INC.**

Genesee County Renovation Environmental Inspection Summary
Parcel ID: 40-11-382-024
Address: 2448 Thomas Street, Flint, Michigan

**Pictures of Asbestos
Containing Material**

Prepared By:	J.M.H
Taken:	07/18/2011
Page:	3

Attachment 2

Basement

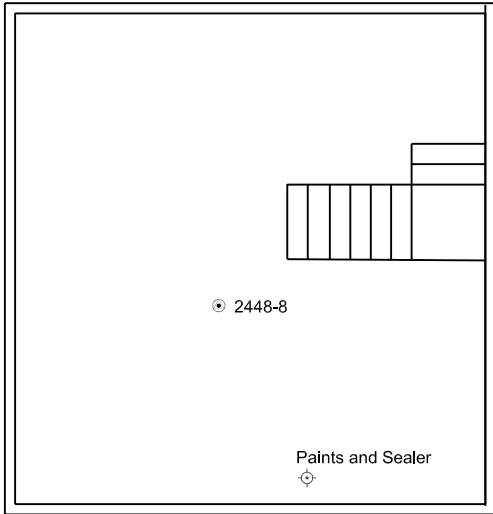

Garage

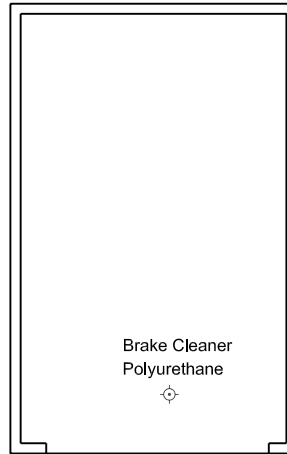

1st Floor

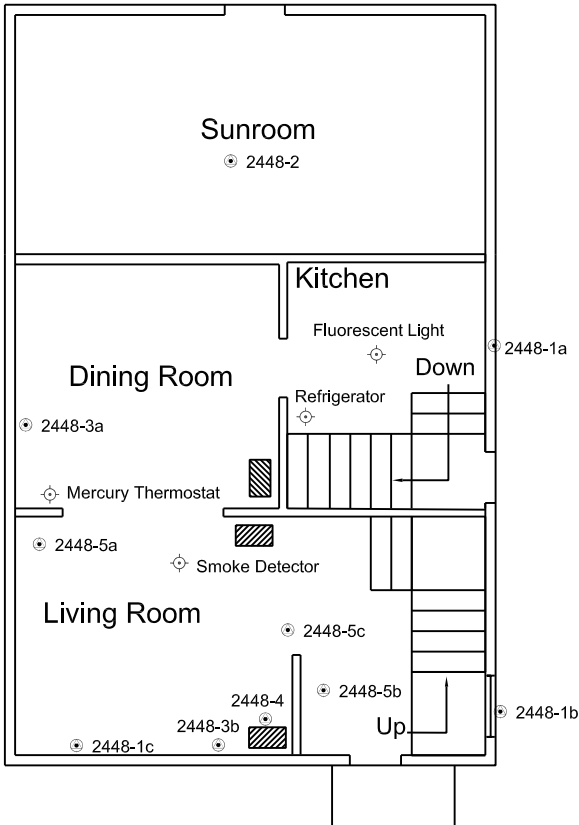

2nd Floor

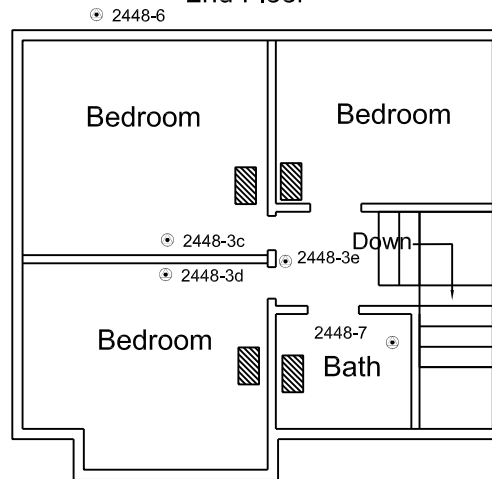

◇ Air Conditioner



GLOBAL
ENVIRONMENTAL
ENGINEERING INC.

- ▨ Asbestos Containing Materials
- Tire
- ◇ Hazardous Material
- ⊙ Asbestos Spl Location

2448 Thomas Street Flint, Michigan	
House Floor Plan	
Last Modified: July 2011	Attachment No.:
Project No.:	2
F1438E	

Attachment 3



Certificate of Laboratory Analysis

Test Method, Polarized Light Microscopy (PLM)

Project: GCLBA - 2448 Thomas Street
Project # F1438E

Report To:

Ms. Julie Herrick
Global Environmental Engineering
6140 Rashelle Drive
Flint, MI 48507

ARI Report # 11-36623
Date Collected: 07/18/11
Date Received: 07/19/11
Date Analyzed: 07/26/11
Date Reported: 07/26/11

Sample Information	Asbestos Type/Percent	Non-Asbestos
Lab ID #: 36623 - 01 Cust. #: 2448-1a Material: Window Caulk Location: Appearance: white,nonfibrous,nonhomogenous Layer: 1 of 1	Asbestos Present: NO No Asbestos Observed	Other - 100%
Lab ID #: 36623 - 02 Cust. #: 2448-1b Material: Window Caulk Location: Appearance: white,nonfibrous,nonhomogenous Layer: 1 of 1	Asbestos Present: NO No Asbestos Observed	Other - 100%
Lab ID #: 36623 - 03 Cust. #: 2448-1c Material: Window Caulk Location: Appearance: grey,nonfibrous,nonhomogenous Layer: 1 of 1	Asbestos Present: NO No Asbestos Observed	Other - 100%

For Layered Samples, each component will be analyzed and reported separately.

Robert T. Letarte Jr., Laboratory Director

Test Method EPA 600/R-93/116 was used to analyze the above samples. Matrix interference and/or resolution limits may yield false results in certain circumstances. Suspect floor tiles containing <1% should be tested with SEM or TEM. This certificate of analysis relates only to the samples tested and to insure the integrity of the results, may only be reproduced in full. This certificate may not be used by the customer to claim product endorsement by NVLAP or any agency of the US Government. APEX Research Inc. is not responsible for the accuracy of the results for layered samples or samples comprising multiple materials. Liability limited to cost of analysis.



NVLAP Lab Code 102118-0



Certificate of Laboratory Analysis

Test Method, Polarized Light Microscopy (PLM)

Project: GCLBA - 2448 Thomas Street
Project # F1438E

Report To:

Ms. Julie Herrick
Global Environmental Engineering
6140 Rashelle Drive
Flint, MI 48507

ARI Report # 11-36623
Date Collected: 07/18/11
Date Received: 07/19/11
Date Analyzed: 07/26/11
Date Reported: 07/26/11

Sample Information	Asbestos Type/Percent	Non-Asbestos
Lab ID #: 36623 - 04 Cust. #: 2448-2 Material: 2x4 Ceiling Tile, White, Perforated Location: Appearance: grey, fibrous, homogenous Layer: 1 of 1	Asbestos Present: NO No Asbestos Observed	Cellulose - 25% Mineral Wool - 25% Perlite - 25% Other - 25%
Lab ID #: 36623 - 05 Cust. #: 2448-3a Material: Plaster Location: Appearance: black, nonfibrous, homogenous Layer: 1 of 1	Asbestos Present: NO No Asbestos Observed	Other - 100%
Lab ID #: 36623 - 06 Cust. #: 2448-3b Material: Plaster Location: Appearance: grey, nonfibrous, homogenous Layer: 1 of 1	Asbestos Present: NO No Asbestos Observed	Other - 100%

For Layered Samples, each component will be analyzed and reported separately.

Robert T. Letarte Jr., Laboratory Director

Test Method EPA 600/R-93/116 was used to analyze the above samples. Matrix interference and/or resolution limits may yield false results in certain circumstances. Suspect floor tiles containing <1% should be tested with SEM or TEM. This certificate of analysis relates only to the samples tested and to insure the integrity of the results, may only be reproduced in full. This certificate may not be used by the customer to claim product endorsement by NVLAP or any agency of the US Government. APEX Research Inc. is not responsible for the accuracy of the results for layered samples or samples comprising multiple materials. Liability limited to cost of analysis.



NVLAP Lab Code 102118-0



Certificate of Laboratory Analysis

Test Method, Polarized Light Microscopy (PLM)

Project: GCLBA - 2448 Thomas Street
Project # F1438E

Report To:

Ms. Julie Herrick
Global Environmental Engineering
6140 Rashelle Drive
Flint, MI 48507

ARI Report # 11-36623
Date Collected: 07/18/11
Date Received: 07/19/11
Date Analyzed: 07/26/11
Date Reported: 07/26/11

Sample Information	Asbestos Type/Percent	Non-Asbestos
Lab ID #: 36623 - 07 Cust. #: 2448-3c Material: Plaster Location: Appearance: grey,nonfibrous,homogenous Layer: 1 of 1	Asbestos Present: NO No Asbestos Observed	Other - 100%
Lab ID #: 36623 - 08 Cust. #: 2448-3d Material: Plaster Location: Appearance: grey,fibrous,homogenous Layer: 1 of 1	Asbestos Present: NO No Asbestos Observed	Cellulose - 2% Other - 98%
Lab ID #: 36623 - 09 Cust. #: 2448-3c Material: Plaster Location: Appearance: grey,fibrous,nonhomogenous Layer: 1 of 1	Asbestos Present: NO No Asbestos Observed	Cellulose - 2% Other - 98%

For Layered Samples, each component will be analyzed and reported separately.

Robert T. Letarte Jr., Laboratory Director

Test Method EPA 600/R-93/116 was used to analyze the above samples. Matrix interference and/or resolution limits may yield false results in certain circumstances. Suspect floor tiles containing <1% should be tested with SEM or TEM. This certificate of analysis relates only to the samples tested and to insure the integrity of the results, may only be reproduced in full. This certificate may not be used by the customer to claim product endorsement by NVLAP or any agency of the US Government. APEX Research Inc. is not responsible for the accuracy of the results for layered samples or samples comprising multiple materials. Liability limited to cost of analysis.



NVLAP Lab Code 102118-0



Certificate of Laboratory Analysis

Test Method, Polarized Light Microscopy (PLM)

Project: GCLBA - 2448 Thomas Street
Project # F1438E

Report To:
Ms. Julie Herrick
Global Environmental Engineering
6140 Rashelle Drive
Flint, MI 48507

ARI Report # 11-36623
Date Collected: 07/18/11
Date Received: 07/19/11
Date Analyzed: 07/26/11
Date Reported: 07/26/11

Sample Information	Asbestos Type/Percent	Non-Asbestos
Lab ID #: 36623 - 10 Cust. #: 2448-4 Material: Duct Wrap Location: Appearance: grey, fibrous, homogenous Layer: 1 of 1	Asbestos Present: YES Chrysotile - 45%	Cellulose - 20% Other - 35%
Lab ID #: 36623 - 11 Cust. #: 2448-5a Material: Popcorn Stucco Location: Appearance: grey, nonfibrous, homogenous Layer: 1 of 1	Asbestos Present: NO No Asbestos Observed	Other - 100%
Lab ID #: 36623 - 12 Cust. #: 2448-5b Material: Popcorn Stucco Location: Appearance: white, nonfibrous, homogenous Layer: 1 of 1	Asbestos Present: NO No Asbestos Observed	Other - 100%

For Layered Samples, each component will be analyzed and reported separately.

Robert T. Letarte Jr., Laboratory Director

Test Method EPA 600/R-93/116 was used to analyze the above samples. Matrix interference and/or resolution limits may yield false results in certain circumstances. Suspect floor tiles containing <1% should be tested with SEM or TEM. This certificate of analysis relates only to the samples tested and to insure the integrity of the results, may only be reproduced in full. This certificate may not be used by the customer to claim product endorsement by NVLAP or any agency of the US Government. APEX Research Inc. is not responsible for the accuracy of the results for layered samples or samples comprising multiple materials. Liability limited to cost of analysis.



NVLAP Lab Code 102118-0



Certificate of Laboratory Analysis

Test Method, Polarized Light Microscopy (PLM)

Project: GCLBA - 2448 Thomas Street
Project # F1438E

Report To:

Ms. Julie Herrick
Global Environmental Engineering
6140 Rashelle Drive
Flint, MI 48507

ARI Report # 11-36623
Date Collected: 07/18/11
Date Received: 07/19/11
Date Analyzed: 07/26/11
Date Reported: 07/26/11

Sample Information	Asbestos Type/Percent	Non-Asbestos
Lab ID #: 36623 - 13 Cust. #: 2448-5c Material: Popcorn Stucco Location: Appearance: white, nonfibrous, homogenous Layer: 1 of 1	Asbestos Present: NO No Asbestos Observed	Other - 100%
Lab ID #: 36623 - 14 Cust. #: 2448-6 Material: Roofing Material Location: Appearance: black, fibrous, nonhomogenous Layer: 1 of 1	Asbestos Present: NO No Asbestos Observed	Fiberglass - 20% Other - 80%
Lab ID #: 36623 - 15 Cust. #: 2448-7 Material: Stucco Location: Appearance: brown, fibrous, nonhomogenous Layer: 1 of 1	Asbestos Present: NO No Asbestos Observed	Cellulose - 30% Other - 70%

For Layered Samples, each component will be analyzed and reported separately.

Robert T. Letarte Jr., Laboratory Director

Test Method EPA 600/R-93/116 was used to analyze the above samples. Matrix interference and/or resolution limits may yield false results in certain circumstances. Suspect floor tiles containing <1% should be tested with SEM or TEM. This certificate of analysis relates only to the samples tested and to insure the integrity of the results, may only be reproduced in full. This certificate may not be used by the customer to claim product endorsement by NVLAP or any agency of the US Government. APEX Research Inc. is not responsible for the accuracy of the results for layered samples or samples comprising multiple materials. Liability limited to cost of analysis.



NVLAP Lab Code 102118-0



Certificate of Laboratory Analysis

Test Method, Polarized Light Microscopy (PLM)

Project: GCLBA - 2448 Thomas Street
Project # F1438E

Report To:
Ms. Julie Herrick
Global Environmental Engineering
6140 Rashelle Drive
Flint, MI 48507

ARI Report # 11-36623
Date Collected: 07/18/11
Date Received: 07/19/11
Date Analyzed: 07/26/11
Date Reported: 07/26/11

Sample Information	Asbestos Type/Percent	Non-Asbestos
Lab ID #: 36623 - 16 Cust. #: 2448-8 Material: Ceiling Tile, 1x1 White Perforated Location: Appearance: brown, fibrous, homogenous Layer: 1 of 1	Asbestos Present: NO No Asbestos Observed	Cellulose - 90% Other - 10%
Lab ID #: Cust. #: Material: Location: Appearance: Layer: of	Asbestos Present:	
Lab ID #: Cust. #: Material: Location: Appearance: Layer: of	Asbestos Present:	

For Layered Samples, each component will be analyzed and reported separately.

Robert T. Letarte Jr., Laboratory Director

Test Method EPA 600/R-93/116 was used to analyze the above samples. Matrix interference and/or resolution limits may yield false results in certain circumstances. Suspect floor tiles containing <1% should be tested with SEM or TEM. This certificate of analysis relates only to the samples tested and to insure the integrity of the results, may only be reproduced in full. This certificate may not be used by the customer to claim product endorsement by NVLAP or any agency of the US Government. APEX Research Inc. is not responsible for the accuracy of the results for layered samples or samples comprising multiple materials. Liability limited to cost of analysis.



NVLAP Lab Code 102118-0

36623

11054 Hi Tech Drive, Whitmore Lake, MI 48189. Phone: (734) 449-9990, Fax (734) 449-9991.
 Web Site: <http://apexresearch-inc.com>. Email: Bob.Letarte@apexresearchlab.com



APEX Research, Inc.

Customer Name: General Environmental Engineering
 Address: 10140 Rossmore Drive
 City, St., Zip: Flint + MI 48507
 Phone: 810-288-9190 Fax: 810-288-9195

Turn Around Times: (Circle One)

Rush

24 hour

Asbestos:

Bulk

Wipe

Point Count

3

PCM

Soil

48 hour

72 hour

Lead:

Bulk

Wipe

Air

Paint

Soil

Other: 5-DAY

TTP (Test Till Positive) no

Mold:

Bulk

Tape

BioSIS

Other

Viable

TEM:

Bulk/NOP

AHERA

EPA Level II

Other

***Terms and conditions on the other side.

Lab Use Only
Log-In: _____
Report: _____
Fax: _____
Verbal: _____
Email: _____

Lab ID	Customer ID #	Material/Location	Volume	Area	Results
1	2448-1a	2448 Thomas Street			TTP
2	2448-1b	Windows Caulk			TTP
3	2448-1c	Window Caulk			TTP
4	2448-2	24 Ceiling Tile White Perforated			TTP
5	2448-3a	Plaster			TTP
6	2448-3b	Plaster			TTP
7	2448-3c	Plaster			TTP
8	2448-3d	Plaster			TTP
9	2448-3e	Plaster			TTP
10	2448-4	Duct Wrap			TTP

Relinquished By: APR Received By: UPS

Date: 7-18-2011 Date: 7-18-2011

Revision Date: June 2011

Relinquished By: Bob Letarte Date: 7-18-2011

Relinquished By: Bob Letarte Date: 7-18-2011

RECEIVED

APEX RESEARCH

36623

11054 Hi Tech Drive, Whitmore Lake, MI 48189. Phone: (734) 449 - 9990, Fax (734) 449 - 9991.
Web Site: <http://apexresearch-inc.com>. Email: Bob.Letarte@apexresearchlab.com



APEX Research, Inc.

Customer Name: Several Environmental Engineering

Date of Survey: 7-18-11

Project: GCCLA

Address: 10140 Roswell Drive

Project # F1438E - 2448 Thomas

City, St., Zip: Flint MI 48507

Contact Person: Julie Herrick

Email: sherrick@gyrobaloi.com

Phone: 810-288-9190 Fax: 810-288-9195

***Terms and conditions on the other side.

Lab Use Only
Log-In: _____
Report: _____
Fax: _____
Verbal: _____
Email: _____

Rush

24 hour

Asbestos:

Bulk

Wipe

Point Count

3

PCM

48 hour

72 hour

Lead:

Bulk

Wipe

Air

Paint

Soil

Other: 5-DAY

TTP yes no
(Test Till Positive)

Mold:

Bulk

Tape

Biosis

Other

Viable

TEM:

Bulk/NOP

AHERA

EPA Level II

Other

Lab ID	Customer ID #	Material/Location	Volume	Area	Results
		2448 Thomas St. Cont.			
11	2448-5a	Popcorn Stucco			TTP
12	2448-5b	Popcorn Stucco			
13	2448-5c	Popcorn Stucco			↓
14	2448-6	Roofing Material			
15	2448-7	Stucco			
	2448-8	Ceiling Tile (x1 unit Perforated)			

Relinquished By: Andi M. DeWard Received By: UPS
Date: 7-18-2011 Date: 7-18-2011

Relinquished By: [Signature]
Date: _____

Relinquished By: _____
Date: _____

JUL 19 2011

Revision Date: June/2011

Attachment 4

NOTIFICATION OF INTENT TO RENOVATE/DEMOLISH



MICHIGAN DEPARTMENT OF NATURAL RESOURCES AND ENVIRONMENT (DNRE) AIR QUALITY DIVISION
 NESHP, 40 CFR Part 61, Subpart M



MICHIGAN DEPARTMENT OF ENERGY, LABOR AND ECONOMIC GROWTH (DELEG), ASBESTOS PROGRAM,
 P.A. 135 OF 1986, AS AMENDED, Section 220 (1-4) or (8)

DNRE/DELEG USE ONLY

Postmark Date ____/____/____ Rec'd Date ____/____/____

Emergency Date ____/____/____ Valid No. _____

OK Send Def Ltr. Date of Def Ltr. ____/____/____

FOLLOW UP ____/____/____ Spoke w/ _____

Comments: _____

Notification No. _____ Trans No. _____

Calculate DELEG Asbestos Project Fee: (1% Project Fee)

Total Project Cost: _____ x 0.01 = _____

Type of Contractor: _____ License No.: _____

Licensing Authority: _____

1. NOTIFICATION:

Date of Notification: _____

Date of Revision(s): _____

Notification Type: Original Revised Canceled Annual

Mark appropriate boxes: (both DNRE and DELEG may apply):

DNRE (NESHP) [260 In. ft./160 sq. ft. or more is threshold]

- Planned Renovation – 10 **working** days notice
- Emergency Renovation
- Scheduled Demolition – 10 **working** days notice
- Intentional Burn – 10 **working** days notice
- Ordered Demolition

DELEG (MIOSHA) [Will not accept annual notifications]

- Demo, Reno, Encap. (>10 In. ft./15 sq. ft.) 10 **calendar** days notice
- Emergency Renovation/Encapsulation

2. PROJECT SCHEDULE:

START DATE END DATE

* Renovation _____ _____

+Asb. Removal _____ _____

+Demolition: _____ _____

Encapsulation: _____ _____

Work Schedule: Please indicate the anticipated days of the week and work hours for the purpose of scheduling a compliance inspection.

Days of the Week Work Hours

Asb. Removal: _____ _____

Demolition: _____ _____

Encapsulation: _____ _____

* Includes setup, build enclosure, asbestos removal, demobilizing, etc.
 +Include **only** those dates you are conducting asbestos removal/demo.

Check here if this is a multi-phased project, attach a schedule showing the start/end date of each phase.

3. ABATEMENT CONTRACTOR:

Internal Project #: _____

Name: _____

Mailing Address: _____

City/State/Zip: _____

E-mail: _____

Contact: _____ Phone: _____

4. DEMOLITION CONTRACTOR:

Internal Project #: _____

Name: _____

Mailing Address: _____

City/State/Zip: _____

E-mail: _____

Contact: _____ Phone: _____

5. FACILITY OWNER: ("Facility" includes Bridges)

Name: _____

Mailing Address: _____

City/State/Zip: _____

E-mail: _____

Contact: _____ Phone: _____

6. FACILITY DESCRIPTION:

Facility Name: _____

Location Address/Description: _____

_____ If Apt. # of units: _____

City/Twp. _____ State: _____ Zip Code: _____

County: _____ Nearest Crossroad: _____

Size: (sq. ft.) _____ No. of Floors: _____ Floor No.: _____

Age: _____ Present Use: _____ Prior Use: _____

Specific Location(s) in Facility: _____

7. DISPOSAL SITE:

Name: _____

Location Address: _____

City/State/Zip: _____

8. WASTE TRANSPORTER 1:

Name: _____

Address: _____

City/State/Zip: _____

Phone: _____

WASTE TRANSPORTER 2:

9. ORDERED DEMOLITIONS: (See NESHP regulations for definition of "Ordered Demolition.") A copy of the official Order must accompany this notification.

Gov't Agency Ordering Demo: _____

Name/Title of Person Signing Order: _____

Date of Order: _____ Date Ordered to Begin: _____

10. IS ASBESTOS PRESENT? Yes No

To be removed prior to demolition

Estimate the amount of asbestos: Include RACM (Regulated Asbestos Containing Material) to be removed, encapsulated, etc. Also include the amount and type (floor tile, roofing, etc.) of non-friable Category I and/or Category II ACM that **will not** be removed prior to demolition. (**NOTE:** In a demolition, cementitious ACM **cannot** remain in a structure, as it is likely to become regulated in the demolition/handling process. It **must** be removed prior to demolition.)

RACM to be Removed	RACM to be Encapsulated	Non-friable ACM not removed prior to demo.		Units of Measure	
		Category I	Category II		
				<input type="checkbox"/> Ln. Ft.	<input type="checkbox"/> Ln. M.
				<input type="checkbox"/> Sq. Ft.	<input type="checkbox"/> Sq. M.
				<input type="checkbox"/> Cu. Ft.*	<input type="checkbox"/> Cu.M.*

*Volume (cubic ft./meters) should be used only if unable to measure by linear/square measure (example: asbestos has fallen off of surface).

(continued on reverse side)

NOTIFICATION OF INTENT TO RENOVATE/DEMOLISH (continued)

11. PROJECT DESCRIPTION: Complete **A) for Renovation** (asbestos removal/encapsulation) and/or **B) for Demolition:**

A) RENOVATION: Mark all surfaces/types of RACM to be removed:

- Piping Fittings Boiler(s) Tanks(s)
 Beam(s) Duct(s) Tunnel(s) Ceiling Tile(s)
 Mag Block Other (describe) _____

Encapsulation (for DELEG): Mark surfaces/types to be encapsulated:

- Piping Fittings Boiler(s) Tank(s)
 Beam(s) Duct(s) Tunnel(s) Ceiling Tile(s)
 Other (describe) _____

Method of removal: Describe how the asbestos will be removed from the surface (example: glove bag, scrape with hand tools, cut in sections and carefully lower, etc.): _____

B) DEMOLITION: Describe the method of demolition of facility, bridge, etc., and indicate if complete or partial. If partial, describe which part of facility bridge, etc., will be demolished: _____

12. ENGINEERING CONTROLS: Describe work practices and engineering controls used to prevent visible emissions before, during, and after removal, and until proper disposal: _____

13. UNEXPECTED ASBESTOS: Describe the steps you intend to follow in the event that unexpected RACM is found or previously non-friable asbestos becomes friable (crumbled, pulverized, reduced to powder, etc.) and therefore regulated: _____

14. PROCEDURE(S) USED TO DETECT THE PRESENCE OF ASBESTOS: **A)** Indicate how you determined whether or not asbestos is in the facility. If analytical sampling was used, describe method of analysis. (The determination of the presence or absence of asbestos must be made prior to submitting a renovation/demolition notification.): _____

B) Name, address, and phone number of company performing asbestos survey: _____

C) Name, accreditation number of inspector, and date of inspection: _____

15. EMERGENCY RENOVATIONS: Date/time of emergency: _____ Describe the sudden, unexpected event: _____

Explain how the event caused unsafe conditions, and/or would cause equipment damage and/or an unreasonable financial burden: _____

16. I certify that an individual trained in the provisions of 40 CFR Part 61, Subpart M, will be on-site during the renovation and during demolition involving RACM above the threshold and/or during an ordered demolition. Evidence that this person has completed the required training will be available for inspection at the renovation or demolition site.

Signature of Owner or Abatement Contractor Date

Signature of Owner or Demolition Contractor Date

17. Signature Requirements for Projects with Negative Pressure Enclosures: (required by DELEG)
Per Section 221(1)(2) of P.A. 135 of 1986, as amended, clearance air monitoring is required for any asbestos abatement project involving 10 linear feet/15 square feet or more of friable material which is performed within a negative pressure enclosure. I (the building owner or lessee) have been advised by the contractor of my responsibility under Act 135 to have clearance air monitoring performed on this project.

Signature of Building Owner or Lessee Date

Signature of Asbestos Abatement Contractor Representative Date

NOTE: It is not mandatory that a signed copy be sent to DELEG unless requested. For affected projects, this section of the notification form must be completed, signed, and made part of your records before the project begins.

18. I certify that the above information is correct:

Printed Name of Owner/Operator Date

Signature of Owner/Operator Date

MAILING ADDRESSES/PHONE NUMBERS: (See Item 1 to determine which agency requirements/regulations are applicable to your project.)

For **Public Act 135 of 1986, as amended, Section 220 (1-4) or (8)**, mail to address below. For more info visit:
<http://www.michigan.gov/asbestos>

MIOSHA Asbestos Program
 DELEG, CSHD
 P.O. Box 30671
 Lansing, MI 48909-8171

517.322.1320 (office), 517.322.1713 (fax)

For **NESHAP Demolitions/Renovations, 40 CFR, Part 61, Subpart M**, mail notifications to the appropriate address below (by county of subject facility): For more info visit <http://www.michigan.gov/deg> click on Air, then Asbestos NESHAP Program.

All Counties (except Wayne County)

NESHAP Asbestos Program
 DNRE, AQD
 P.O. Box 30260
 Lansing, MI 48909-7760

517.373.7064 (Revision Line)

Wayne County Only

NESHAP Asbestos Program
 Detroit Field Office, DNRE, AQD
 Cadillac Place, Suite 2-300
 3058 West Grand Boulevard
 Detroit, MI 48202

313.456.4686

Applicability

The Project or Program to which the construction work covered by this contract pertains is being assisted by the United States of America and the following Federal Labor Standards Provisions are included in this Contract pursuant to the provisions applicable to such Federal assistance.

A. 1. (i) Minimum Wages. All laborers and mechanics employed or working upon the site of the work will be paid unconditionally and not less often than once a week, and without subsequent deduction or rebate on any account (except such payroll deductions as are permitted by regulations issued by the Secretary of Labor under the Copeland Act (29 CFR Part 3), the full amount of wages and bona fide fringe benefits (or cash equivalents thereof) due at time of payment computed at rates not less than those contained in the wage determination of the Secretary of Labor which is attached hereto and made a part hereof, regardless of any contractual relationship which may be alleged to exist between the contractor and such laborers and mechanics. Contributions made or costs reasonably anticipated for bona fide fringe benefits under Section I(b)(2) of the Davis-Bacon Act on behalf of laborers or mechanics are considered wages paid to such laborers or mechanics, subject to the provisions of 29 CFR 5.5(a)(1)(iv); also, regular contributions made or costs incurred for more than a weekly period (but not less often than quarterly) under plans, funds, or programs, which cover the particular weekly period, are deemed to be constructively made or incurred during such weekly period.

Such laborers and mechanics shall be paid the appropriate wage rate and fringe benefits on the wage determination for the classification of work actually performed, without regard to skill, except as provided in 29 CFR 5.5(a)(4). Laborers or mechanics performing work in more than one classification may be compensated at the rate specified for each classification for the time actually worked therein: Provided, That the employer's payroll records accurately set forth the time spent in each classification in which work is performed. The wage determination (including any additional classification and wage rates conformed under 29 CFR 5.5(a)(1)(ii) and the Davis-Bacon poster (WH-1321) shall be posted at all times by the contractor and its subcontractors at the site of the work in a prominent and accessible, place where it can be easily seen by the workers.

(ii) (a) Any class of laborers or mechanics which is not listed in the wage determination and which is to be employed under the contract shall be classified in conformance with the wage determination. HUD shall approve an additional classification and wage rate and fringe benefits therefor only when the following criteria have been met:

- (1)** The work to be performed by the classification requested is not performed by a classification in the wage determination; and
- (2)** The classification is utilized in the area by the construction industry; and
- (3)** The proposed wage rate, including any bona fide fringe benefits, bears a reasonable relationship to the wage rates contained in the wage determination.

(b) If the contractor and the laborers and mechanics to be employed in the classification (if known), or their representatives, and HUD or its designee agree on the classification and wage rate (including the amount designated for fringe benefits where

appropriate), a report of the action taken shall be sent by HUD or its designee to the Administrator of the Wage and Hour Division, Employment Standards Administration, U.S. Department of Labor, Washington, D.C. 20210. The Administrator, or an authorized representative, will approve, modify, or disapprove every additional classification action within 30 days of receipt and so advise HUD or its designee or will notify HUD or its designee within the 30-day period that additional time is necessary. (Approved by the Office of Management and Budget under OMB control number 1215-0140.)

(c) In the event the contractor, the laborers or mechanics to be employed in the classification or their representatives, and HUD or its designee do not agree on the proposed classification and wage rate (including the amount designated for fringe benefits, where appropriate), HUD or its designee shall refer the questions, including the views of all interested parties and the recommendation of HUD or its designee, to the Administrator for determination. The Administrator, or an authorized representative, will issue a determination within 30 days of receipt and so advise HUD or its designee or will notify HUD or its designee within the 30-day period that additional time is necessary. (Approved by the Office of Management and Budget under OMB Control Number 1215-0140.)

(d) The wage rate (including fringe benefits where appropriate) determined pursuant to subparagraphs (1)(ii)(b) or (c) of this paragraph, shall be paid to all workers performing work in the classification under this contract from the first day on which work is performed in the classification.

(iii) Whenever the minimum wage rate prescribed in the contract for a class of laborers or mechanics includes a fringe benefit which is not expressed as an hourly rate, the contractor shall either pay the benefit as stated in the wage determination or shall pay another bona fide fringe benefit or an hourly cash equivalent thereof.

(iv) If the contractor does not make payments to a trustee or other third person, the contractor may consider as part of the wages of any laborer or mechanic the amount of any costs reasonably anticipated in providing bona fide fringe benefits under a plan or program, Provided, That the Secretary of Labor has found, upon the written request of the contractor, that the applicable standards of the Davis-Bacon Act have been met. The Secretary of Labor may require the contractor to set aside in a separate account assets for the meeting of obligations under the plan or program. (Approved by the Office of Management and Budget under OMB Control Number 1215-0140.)

2. Withholding. HUD or its designee shall upon its own action or upon written request of an authorized representative of the Department of Labor withhold or cause to be withheld from the contractor under this contract or any other Federal contract with the same prime contractor, or any other Federally-assisted contract subject to Davis-Bacon prevailing wage requirements, which is held by the same prime contractor so much of the accrued payments or advances as may be considered necessary to pay laborers and mechanics, including apprentices, trainees and helpers, employed by the contractor or any subcontractor the full amount of wages required by the contract. In the event of failure to pay any laborer or mechanic, including any apprentice, trainee or helper, employed or working on the site of the work, all or part

of the wages required by the contract, HUD or its designee may, after written notice to the contractor, sponsor, applicant, or owner, take such action as may be necessary to cause the suspension of any further payment, advance, or guarantee of funds until such violations have ceased. HUD or its designee may, after written notice to the contractor, disburse such amounts withheld for and on account of the contractor or subcontractor to the respective employees to whom they are due. The Comptroller General shall make such disbursements in the case of direct Davis-Bacon Act contracts.

3. (i) Payrolls and basic records. Payrolls and basic records relating thereto shall be maintained by the contractor during the course of the work preserved for a period of three years thereafter for all laborers and mechanics working at the site of the work. Such records shall contain the name, address, and social security number of each such worker, his or her correct classification, hourly rates of wages paid (including rates of contributions or costs anticipated for bona fide fringe benefits or cash equivalents thereof of the types described in Section I(b)(2)(B) of the Davis-bacon Act), daily and weekly number of hours worked, deductions made and actual wages paid. Whenever the Secretary of Labor has found under 29 CFR 5.5 (a)(1)(iv) that the wages of any laborer or mechanic include the amount of any costs reasonably anticipated in providing benefits under a plan or program described in Section I(b)(2)(B) of the Davis-Bacon Act, the contractor shall maintain records which show that the commitment to provide such benefits is enforceable, that the plan or program is financially responsible, and that the plan or program has been communicated in writing to the laborers or mechanics affected, and records which show the costs anticipated or the actual cost incurred in providing such benefits. Contractors employing apprentices or trainees under approved programs shall maintain written evidence of the registration of apprenticeship programs and certification of trainee programs, the registration of the apprentices and trainees, and the ratios and wage rates prescribed in the applicable programs. (Approved by the Office of Management and Budget under OMB Control Numbers 1215-0140 and 1215-0017.)

(ii) (a) The contractor shall submit weekly for each week in which any contract work is performed a copy of all payrolls to HUD or its designee if the agency is a party to the contract, but if the agency is not such a party, the contractor will submit the payrolls to the applicant sponsor, or owner, as the case may be, for transmission to HUD or its designee. The payrolls submitted shall set out accurately and completely all of the information required to be maintained under 29 CFR 5.5(a)(3)(i). This information may be submitted in any form desired. Optional Form WH-347 is available for this purpose and may be purchased from the Superintendent of Documents (Federal Stock Number 029-005-00014-1), U.S. Government Printing Office, Washington, DC 20402. The prime contractor is responsible for the submission of copies of payrolls by all subcontractors. (Approved by the Office of Management and Budget under OMB Control Number 1215-0149.)

(b) Each payroll submitted shall be accompanied by a "Statement of Compliance," signed by the contractor or subcontractor or his or her agent who pays or supervises the payment of the persons employed under the contract and shall certify the following:

(1) That the payroll for the payroll period contains the information required to be maintained under 29 CFR 5.5 (a)(3)(i) and that such information is correct and complete;

(2) That each laborer or mechanic (including each helper, apprentice, and trainee) employed on the contract during the payroll

period has been paid the full weekly wages earned, without rebate, either directly or indirectly, and that no deductions have been made either directly or indirectly from the full wages earned, other than permissible deductions as set forth in 29 CFR Part 3;

(3) That each laborer or mechanic has been paid not less than the applicable wage rates and fringe benefits or cash equivalents for the classification of work performed, as specified in the applicable wage determination incorporated into the contract.

(c) The weekly submission of a properly executed certification set forth on the reverse side of Optional Form WH-347 shall satisfy the requirement for submission of the "Statement of Compliance" required by subparagraph A.3.(ii)(b).

(d) The falsification of any of the above certifications may subject the contractor or subcontractor to civil or criminal prosecution under Section 1001 of Title 18 and Section 231 of Title 31 of the United States Code.

(iii) The contractor or subcontractor shall make the records required under subparagraph A.3.(i) available for inspection, copying, or transcription by authorized representatives of HUD or its designee or the Department of Labor, and shall permit such representatives to interview employees during working hours on the job. If the contractor or subcontractor fails to submit the required records or to make them available, HUD or its designee may, after written notice to the contractor, sponsor, applicant or owner, take such action as may be necessary to cause the suspension of any further payment, advance, or guarantee of funds. Furthermore, failure to submit the required records upon request or to make such records available may be grounds for debarment action pursuant to 29 CFR 5.12.

4. Apprentices and Trainees.

(i) Apprentices. Apprentices will be permitted to work at less than the predetermined rate for the work they performed when they are employed pursuant to and individually registered in a bona fide apprenticeship program registered with the U.S. Department of Labor, Employment and Training Administration, Office of Apprenticeship Training, Employer and Labor Services, or with a State Apprenticeship Agency recognized by the Office, or if a person is employed in his or her first 90 days of probationary employment as an apprentice in such an apprenticeship program, who is not individually registered in the program, but who has been certified by the Office of Apprenticeship Training, Employer and Labor Services or a State Apprenticeship Agency (where appropriate) to be eligible for probationary employment as an apprentice. The allowable ratio of apprentices to journeymen on the job site in any craft classification shall not be greater than the ratio permitted to the contractor as to the entire work force under the registered program. Any worker listed on a payroll at an apprentice wage rate, who is not registered or otherwise employed as stated above, shall be paid not less than the applicable wage rate on the wage determination for the classification of work actually performed. In addition, any apprentice performing work on the job site in excess of the ratio permitted under the registered program shall be paid not less than the applicable wage rate on the wage determination for the work actually performed. Where a contractor is performing construction on a project in a locality other than that in which its program is registered, the ratios and wage rates (expressed in percentages of the journeyman's hourly rate) specified in the contractor's or subcontractor's registered program shall be observed. Every apprentice must be paid at not less than the rate specified in the registered program for the apprentice's level of progress, expressed as a percentage of the

journeymen hourly rate specified in the applicable wage determination. Apprentices shall be paid fringe benefits in accordance with the provisions of the apprenticeship program. If the apprenticeship program does not specify fringe benefits, apprentices must be paid the full amount of fringe benefits listed on the wage determination for the applicable classification. If the Administrator determines that a different practice prevails for the applicable apprentice classification, fringes shall be paid in accordance with that determination. In the event the Office of Apprenticeship Training, Employer and Labor Services, or a State Apprenticeship Agency recognized by the Office, withdraws approval of an apprenticeship program, the contractor will no longer be permitted to utilize apprentices at less than the applicable predetermined rate for the work performed until an acceptable program is approved.

(ii) Trainees. Except as provided in 29 CFR 5.16, trainees will not be permitted to work at less than the predetermined rate for the work performed unless they are employed pursuant to and individually registered in a program which has received prior approval, evidenced by formal certification by the U.S. Department of Labor, Employment and Training Administration. The ratio of trainees to journeymen on the job site shall not be greater than permitted under the plan approved by the Employment and Training Administration. Every trainee must be paid at not less than the rate specified in the approved program for the trainee's level of progress, expressed as a percentage of the journeyman hourly rate specified in the applicable wage determination. Trainees shall be paid fringe benefits in accordance with the provisions of the trainee program. If the trainee program does not mention fringe benefits, trainees shall be paid the full amount of fringe benefits listed on the wage determination unless the Administrator of the Wage and Hour Division determines that there is an apprenticeship program associated with the corresponding journeyman wage rate on the wage determination which provides for less than full fringe benefits for apprentices. Any employee listed on the payroll at a trainee rate who is not registered and participating in a training plan approved by the Employment and Training Administration shall be paid not less than the applicable wage rate on the wage determination for the work actually performed. In addition, any trainee performing work on the job site in excess of the ratio permitted under the registered program shall be paid not less than the applicable wage rate on the wage determination for the work actually performed. In the event the Employment and Training Administration withdraws approval of a training program, the contractor will no longer be permitted to utilize trainees at less than the applicable predetermined rate for the work performed until an acceptable program is approved.

(iii) Equal employment opportunity. The utilization of apprentices, trainees and journeymen under 29 CFR Part 5 shall be in conformity with the equal employment opportunity requirements of Executive Order 11246, as amended, and 29 CFR Part 30.

5. Compliance with Copeland Act requirements. The contractor shall comply with the requirements of 29 CFR Part 3 which are incorporated by reference in this contract

6. Subcontracts. The contractor or subcontractor will insert in any subcontracts the clauses contained in subparagraphs 1 through 11 of this paragraph A and such other clauses as HUD or its designee may by appropriate instructions require, and a copy of the applicable prevailing wage decision, and also a clause requiring the subcontractors to include these clauses in any lower tier subcontracts. The prime contractor shall be responsible for the compliance by any subcontractor or lower tier subcontractor with all the contract clauses in this paragraph.

7. Contract termination; debarment. A breach of the contract clauses in 29 CFR 5.5 may be grounds for termination of the contract and for debarment as a contractor and a subcontractor as provided in 29 CFR 5.12.

8. Compliance with Davis-Bacon and Related Act Requirements. All rulings and interpretations of the Davis-Bacon and Related Acts contained in 29 CFR Parts 1, 3, and 5 are herein incorporated by reference in this contract

9. Disputes concerning labor standards. Disputes arising out of the labor standards provisions of this contract shall not be subject to the general disputes clause of this contract. Such disputes shall be resolved in accordance with the procedures of the Department of Labor set forth in 29 CFR Parts 5, 6, and 7. Disputes within the meaning of this clause include disputes between the contractor (or any of its subcontractors) and HUD or its designee, the U.S. Department of Labor, or the employees or their representatives.

10. (i) Certification of Eligibility. By entering into this contract the contractor certifies that neither it (nor he or she) nor any person or firm who has an interest in the contractor's firm is a person or firm ineligible to be awarded Government contracts by virtue of Section 3(a) of the Davis-Bacon Act or 29 CFR 5.12(a)(1) or to be awarded HUD contracts or participate in HUD programs pursuant to 24 CFR Part 24.

(ii) No part of this contract shall be subcontracted to any person or firm ineligible for award of a Government contract by virtue of Section 3(a) of the Davis-Bacon Act or 29 CFR 5.12(a)(1) or to be awarded HUD contracts or participate in HUD programs pursuant to 24 CFR Part 24.

(iii) The penalty for making false statements is prescribed in the U.S. Criminal Code, 18 U.S.C. 1001. Additionally, U.S. Criminal Code, Section 1 01 0, Title 18, U.S.C., "Federal Housing Administration transactions", provides in part: "Whoever, for the purpose of . . . influencing in any way the action of such Administration.... makes, utters or publishes any statement knowing the same to be false..... shall be fined not more than \$5,000 or imprisoned not more than two years, or both."

11. Complaints, Proceedings, or Testimony by Employees. No laborer or mechanic to whom the wage, salary, or other labor standards provisions of this Contract are applicable shall be discharged or in any other manner discriminated against by the Contractor or any subcontractor because such employee has filed any complaint or instituted or caused to be instituted any proceeding or has testified or is about to testify in any proceeding under or relating to the labor standards applicable under this Contract to his employer.

B. Contract Work Hours and Safety Standards Act. The provisions of this paragraph B are applicable only where the amount of the prime contract exceeds \$100,000. As used in this paragraph, the terms "laborers" and "mechanics" include watchmen and guards.

(1) Overtime requirements. No contractor or subcontractor contracting for any part of the contract work which may require or involve the employment of laborers or mechanics shall require or permit any such laborer or mechanic in any workweek in which he or she is employed on such work to work in excess of 40 hours in such workweek unless such laborer or mechanic receives compensation at a rate not less than one and one-half times the basic rate of pay for all hours worked in excess of 40 hours in such workweek.

(2) Violation; liability for unpaid wages; liquidated damages. In the event of any violation of the clause set forth in subpara-

graph (1) of this paragraph, the contractor and any subcontractor responsible therefor shall be liable for the unpaid wages. In addition, such contractor and subcontractor shall be liable to the United States (in the case of work done under contract for the District of Columbia or a territory, to such District or to such territory), for liquidated damages. Such liquidated damages shall be computed with respect to each individual laborer or mechanic, including watchmen and guards, employed in violation of the clause set forth in subparagraph (1) of this paragraph, in the sum of \$10 for each calendar day on which such individual was required or permitted to work in excess of the standard workweek of 40 hours without payment of the overtime wages required by the clause set forth in sub paragraph (1) of this paragraph.

(3) Withholding for unpaid wages and liquidated damages. HUD or its designee shall upon its own action or upon written request of an authorized representative of the Department of Labor withhold or cause to be withheld, from any moneys payable on account of work performed by the contractor or subcontractor under any such contract or any other Federal contract with the same prime contract, or any other Federally-assisted contract subject to the Contract Work Hours and Safety Standards Act which is held by the same prime contractor such sums as may be determined to be necessary to satisfy any liabilities of such contractor or subcontractor for unpaid wages and liquidated damages as provided in the clause set forth in subparagraph (2) of this paragraph.

(4) Subcontracts. The contractor or subcontractor shall insert in any subcontracts the clauses set forth in subparagraph (1) through (4) of this paragraph and also a clause requiring the subcontractors to include these clauses in any lower tier subcontracts. The prime contractor shall be responsible for compliance by any subcontractor or lower tier subcontractor with the clauses set forth in subparagraphs (1) through (4) of this paragraph.

C. Health and Safety. The provisions of this paragraph C are applicable only where the amount of the prime contract exceeds \$100,000.

(1) No laborer or mechanic shall be required to work in surroundings or under working conditions which are unsanitary, hazardous, or dangerous to his health and safety as determined under construction safety and health standards promulgated by the Secretary of Labor by regulation.

(2) The Contractor shall comply with all regulations issued by the Secretary of Labor pursuant to Title 29 Part 1926 and failure to comply may result in imposition of sanctions pursuant to the Contract Work Hours and Safety Standards Act, 40 USC 3701 et seq.

(3) The Contractor shall include the provisions of this paragraph in every subcontract so that such provisions will be binding on each subcontractor. The Contractor shall take such action with respect to any subcontract as the Secretary of Housing and Urban Development or the Secretary of Labor shall direct as a means of enforcing such provisions.

**EQUAL OPPORTUNITY CLAUSE
(EXECUTIVE ORDER 11246)**

"During the performance of this contract, the contractor agrees as follows:

"(1) The contractor will not discriminate against any employee or applicant for Employment because of race, creed, color, or national origin. The contractor will take affirmative action to ensure that applicants are employed, and that employees are treated during employment, without regard to their race, creed, color, or national origin. Such action shall include, but not be limited to the following: employment, upgrading, demotion, or transfer; recruitment or recruitment advertising; layoff or termination; rates of pay or other forms of compensation; and selection for training, including apprenticeship. The contractor agrees to post in conspicuous places, available to employees and applicants for employment, notices to be provided by the contracting officer setting forth the provisions of this nondiscrimination clause.

"(2) The contractor will, in all solicitations or advertisements for employees placed by or on behalf of the contractor, state that all qualified applicants will receive consideration for employment without regard to race, creed, color, or national origin.

"(3) The contractor will send to each labor union or representative of workers with which he has a collective bargaining agreement or other contract or understanding, a notice, to be provided by the agency contracting officer, advising the labor union or workers' representative of the contractor's commitments under Section 202 of Executive Order No. 11246 of September 24, 1965, and shall post copies of the notice in conspicuous places available to employees and applicants for employment.

"(4) The contractor will comply with all provisions of Executive Order No. 11246 of Sept. 24, 1965, and of the rules, regulations, and relevant orders of the Secretary of Labor.

"(5) The contractor will furnish all information and reports required by Executive Order No. 11246 of September 24, 1965, and by the rules, regulations, and orders of the Secretary of Labor, or pursuant thereto, and will permit access to his books, records, and accounts by the contracting agency and the Secretary of Labor for purposes of investigation to ascertain compliance with such rules, regulations, and orders.

"(6) In the event of the contractor's noncompliance with the nondiscrimination clauses of this contract or with any of such rules, regulations, or orders, this contract may be cancelled, terminated or suspended in whole or in part and the contractor may be declared ineligible for further Government contracts in accordance with procedures authorized in Executive Order No. 11246 of Sept 24, 1965, and such other sanctions may be imposed and remedies invoked as provided in Executive Order No. 11246 of September 24, 1965, or by rule, regulation, or order of the Secretary of Labor, or as otherwise provided by law.

"(7) The contractor will include the provisions of Paragraphs (1) through (7) in every subcontract or purchase order unless exempted by rules, regulations, or orders of the Secretary of Labor issued pursuant to Section 204 of Executive Order No. 11246 of Sept. 24, 1965, so that such provisions will be binding upon each subcontractor or vendor. The contractor will take such action with respect to any subcontract or purchase order as the contracting agency may direct as a means of enforcing such provisions including sanctions for noncompliance: Provided, however, That in the event the contractor becomes involved in, or is threatened with, litigation with a subcontractor or vendor as a result of such direction by the contracting agency, the contractor may request the United States to enter into such litigation to protect the interests of the United States."

SECTION 3 CLAUSE

All Section 3 covered contracts shall include the following clause (referred to as the “Section 3 Clause”):

A. The work to be performed under this contract is subject to the requirements of Section 3 of the Housing and Urban Development Act of 1968, as amended, [12 U.S.C. 1701u](#) (section 3). The purpose of section 3 is to ensure that employment and other economic opportunities generated by HUD assistance or HUD-assisted projects covered by section 3, shall, to the greatest extent feasible, be directed to low- and very low-income persons, particularly persons who are recipients of HUD assistance for housing.

B. The parties to this contract agree to comply with HUD's regulations in 24 CFR Part 135, which implement section 3. As evidenced by their execution of this contract, the parties to this contract certify that they are under no contractual or other impediment that would prevent them from complying with the part 135 regulations.

C. The contractor agrees to send to each labor organization or representative of workers with which the contractor has a collective bargaining agreement or other understanding, if any, a notice advising the labor organization or workers' representative of the contractor's commitments under this section 3 clause, and will post copies of the notice in conspicuous places at the work site where both employees and applicants for training and employment positions can see the notice. The notice shall describe the section 3 preference, shall set forth minimum number and job titles subject to hire, availability of apprenticeship and training positions, the qualifications for each; and the name and location of the person(s) taking applications for each of the positions; and the anticipated date the work shall begin.

D. The contractor agrees to include this section 3 clause in every subcontract subject to compliance with regulations in 24 CFR Part 135, and agrees to take appropriate action, as provided in an applicable provision of the subcontract or in this section 3 clause, upon a finding that the subcontractor is in violation of the regulations in 24 CFR Part 135. The contractor will not subcontract with any subcontractor where the contractor has notice or knowledge that the subcontractor has been found in violation of the regulations in 24 CFR Part 135.

E. The contractor will certify that any vacant employment positions, including training positions, that are filled (1) after the contractor is selected by before the contract is executed, and (2) with persons other than those to whom the regulations of 24 CFR part 135 require employment opportunities to be directed, were not filled to circumvent the contractor's obligations under 24 CFR part 135.

F. Noncompliance with HUD's regulations in 24 CFR part 135 may result in sanctions, termination of this contract for default, and debarment or suspension from future HUD assisted contracts.

G. With respect to work performed in connection with section 3 covered Indian housing assistance, section 7(b) of the Indian Self-Determination and Education Assistance Act (25 U.S.C. 450e) also applies to the work to be performed under this contract. Section 7(b) requires that to the greatest extent feasible (i) preference in the award of contracts and subcontracts shall be given to Indian organizations and Indian-owned Economic Enterprises. Parties to this contract that are subject to the provisions of section 3 and section 7(b) agree to comply with section 3 to the maximum extent feasible, but not in derogation of compliance with section 7(b).

City of Flint – Section 3 Plan Addendum

This document provides specific direction for certification and reporting of the implementation of the City of Flint's Section 3 Standard Operating Procedures.

Title 24--Housing and Urban Development

CHAPTER I--OFFICE OF ASSISTANT SECRETARY FOR EQUAL OPPORTUNITY,
DEPARTMENT OF HOUSING AND URBAN DEVELOPMENT
PART 135--ECONOMIC OPPORTUNITIES FOR LOW- AND VERY LOW-INCOME
PERSONS

Resident Requirements

Each contractor conducting services on covered projects under the guideline Title 24 Code of Federal Regulation Part 135 is to provide the City of Flint a current list of employees that will be assigned to accomplish activities under the covered contract within 10 business days of the contract execution date.

Section 3 is triggered when the normal completion of construction and rehabilitation projects creates the need for new employment, contracting or training opportunities beyond the list of employees provided at the execution of the contract including, but not limited to, administrative, managerial, clerical, service, and building trades positions.

Employee registers should be submitted monthly on the Monthly Status Report Worksheet along with the monthly activity report/pay request. Section 3 compliance will be monitored monthly by verifying the names on the initial employee list with monthly activity reports and/or pay requests that list new employees in the payroll. Thirty percent of new hires, trainees or contractors are required to be Section 3 eligible. If accomplishing the contract does not require new employees, training or contractors, Section 3 is not triggered.

All potential Section 3 eligible new hires must register with the Mott Community College Workforce Development and Career Services Department before they begin working. MCC Workforce Development (MCC WFD) will certify that new hires are Section 3 eligible. MCC WFD will provide the new hire Section 3 certification documentation to the identified Contractor and the City of Flint.

If the contractor/sub recipient is unable to identify Section 3 eligible individuals with the skill sets needed to accomplish the work that is needed, MCC Workforce Development has a pool of Building Construction Trade graduates that are Section 3 certified. The contractor should contact MCC to secure certified employees.

MCC WFD will provide the City of Flint with monthly reports to identify the number and placement of Section 3 certified workers.

Business Concerns

Each contractor conducting services on covered projects under the guideline Title 24 Code of Federal Regulation Part 135 is to provide the City of Flint a current list of contractors that will be assigned to accomplish activities under the covered contract within 10 business days of the contract execution date.

Section 3 is triggered when the normal completion of construction and rehabilitation projects creates the need for new employment, contracting or training opportunities beyond the list of contractors provided at the execution of the contract.

Each contractor and subcontractor demonstrates compliance with the requirements of this part by awarding at least 10 percent of contracts to Section 3 Business Concerns.

If the Contract Holder identifies a Section 3 Business Concern for sub contracting purposes, submit Section 3 Business Concern documentation for certification to the City of Flint Section 3 Coordinator to certify each Business Concern. Each Section 3 eligible employee of that Contractor must be directed to Mott Community College Workforce Development and Career Services Department for certification.

Contractor registers should be submitted monthly on the Monthly Status Report Worksheet along with the monthly activity report/pay request. Section 3 compliance will be monitored monthly by verifying the companies on the initial employee list with monthly activity reports and/or pay requests that list new employees in the payroll. If accomplishing the contract does not require new contractors, Section 3 is not triggered.

A list is being compiled of Section 3 Business Concerns. For a list of eligible businesses, please contact the Department of Community and Economic Development.

Certification for Resident Seeking Section 3 Training and Employment

Preference

Eligibility Preference

A Section 3 resident seeking the preference in training and employment provided by this project shall certify or submit evidence to Mott Community College Workforce Development and recipient contractor/subcontractor that the person is a Section 3 resident.

I, _____, am a legal resident of the City of Flint

(print name)

and meet the income eligibility guidelines for a low- or very-low-income person for this area.

My permanent address is:

I have attached the following documentation as evidence of my status:

- Copy of lease
- Copy of receipt of public assistance
- Copy of Evidence of participation in a public assistance program
- Other evidence
 - Tax return
 - Pay stub
 - Social Security Annual Income Report
 - Unemployment rejection letter
 - DHS denial letter
 - Notarized letter of support from other individual

Signature _____

Print Name _____

Date _____



Open Enrollment

Monday - Thursday ONLY

Arrive 15 minutes early

Intake is at 9AM-or-1PM

MUST be on time!!!

Intake is 3-3 ½ hours

NO children PLEASE!

Mott Community College (MCC) – Workforce & Career Development Department is pleased to share services offered through the Workforce Investment Act (WIA) Program, which are designed to assist with **employment and career goals.**

MCC provides services through the WIA Title I **Adult, Dislocated and Older Youth Worker Programs.** All participants must be **18 years of age or older; a citizen of the United States or an eligible non-citizen and registered with selective service** (if applicable). Dislocated Worker Program participants must also be terminated or laid off or have received a notice of termination or layoff from employment; and eligible for/or exhausted his/her entitlement to unemployment compensation. **If the previous requirements are not met, participants must have worked 90 days consecutively and unlikely to return.**

Both programs offer three levels of service: staff-assisted core, intensive and training services. Participants are involved in activities such as Individual Job Development, Advanced Job Club, Advanced Screened Referrals and Follow-Up Services, which are tailored to meet individual needs. Supportive Services may be available on a limited basis, to those who qualify for the purpose of enabling the successful participation and completion of program services.

To take advantage of these program opportunities, individuals must register with and receive core services from the Employment Services Office; complete the WIA Registration process and meet the program eligibility and documentation requirements.

Please call **(810) 232-2555** if you have any questions.

The following documentation will be needed at the time of your appointment as it applies to your situation.

- **Career Alliance Referral Forms from Employment Services**
- **Valid Driver's License or State ID**
- **Social Security Card**
- **Birth Certificate (If no valid ID)**
- **Adult Workers (*Proof of Family Size & Proof of Income – Most Recent Check Stub*)**
- **Spouse most recent check stub (*If married*)**
- **Most Recent Tax Return (To verify Family size)**
- **Dislocated Workers (*Most Current UA Check Stub, UA Determination Notice*)**
- **Letter of dismissal from last employer-if available**
- **Medical Cards / Bridge Card**
- **DHS Statement of Income**
- **SSI / SSD Statement of Income**
- **Copy of WorkKeys assessment results**
- **DD-214, Military Transfer/Discharge Paper**

We look forward to working with you soon!

**Charles Stewart Mott Community College
Workforce & Career Development – WIA Program**

709 North Saginaw Street - Flint, Michigan 48503 • (810) 232-2555 (Voice & TTY) – (810) 232-4981 (Fax)

AN EQUAL OPPORTUNITY PROGRAM/AFFIRMATIVE ACTION EMPLOYER
AUXILIARY AIDS AND SERVICES ARE AVAILABLE TO PERSONS WITH DISABILITIES UPON REQUEST.

Certification for Business Concern Seeking Section 3 Preference in Contracting and Demonstration of Capacity

Name of Business _____ Phone/Fax _____

Address of Business _____

Type of Business: Corporation Partnership Sole Proprietorship

Type of Business Activity: _____

Attached is the following documentation as evidence of status:

For all business entities (as applicable):

- | | |
|--|---|
| <input type="checkbox"/> Copy of Articles of Incorporation | <input type="checkbox"/> Certificate of Good Standing |
| <input type="checkbox"/> Assumed Business Name Certificate | <input type="checkbox"/> Partnership Agreement |
| <input type="checkbox"/> List of owners/stockholders and 51% ownership of each | <input type="checkbox"/> Corporation Annual Report |
| <input type="checkbox"/> Organization chart with names and titles and brief function statement | <input type="checkbox"/> Latest Board minutes appointing officers |
| | <input type="checkbox"/> Additional documentation |

For business claiming status as a Section 3 resident-owned enterprise:

Certification for Section 3 Residents (at least 51% of the business owners)

For Business claiming Section 3 status by subcontracting 25% of the dollar award to

qualified Section 3 Business:

- List of subcontracted Section 3 business(es) and subcontract amount
- This certification & all supporting documentation for each subcontracted Section 3 Business

For business claiming Section 3 status, claiming at least 30 percent of their workforce are currently Section 3 residents or were Section 3 eligible residents within 3 years of date of first employment with the business:

- List of all current full time employees
- List of employees claiming Section 3 status
- Certification for Section 3 Residents (at least 30% of all current full-time employees) with supporting documentation showing Section 3 status immediately prior to the date of first hire

Evidence of ability to perform successfully under the terms and conditions of the proposed contract:

- Current financial statement or Income Tax Return
- Statement of ability to comply with public policy (federal, state or city work experience)
- List of owned equipment
- List of all contracts for the past two years

Authorized Name, Title and Signature

Date _____

Please submit documentation of the following items to Tracy Atkinson at City of Flint, Dept. of Community and Economic Development, 1101 S. Saginaw St., Flint, Michigan 48502, tatkinson@cityofflint.com, 810-766-7426 ext. 3059, 810-766-7351 (fax)

City of Flint Housing Administration Division
SECTION 3 DEVELOPER/SUBGRANTEE EMPLOYMENT ROSTER
Submitted on Execution of Contract

Contractor Name: _____ Contact Person: _____ Telephone: _____ Fax: _____

Project Name: _____ Contact Number: _____ Reporting Period: _____

Please list all current employees on your project – Identify Section 3 Certified employees

<u>Name</u>	<u>Address</u>	<u>Telephone</u>	<u>Starting Date</u>	<u>Ending Date</u>	<u>Position</u>
1.					
2.					
3.					
4.					
5.					
6.					
7.					
8.					
9.					
10.					

Signature _____ Date: _____

To be submitted with monthly activity/pay requests

City of Flint Housing Administration Division
SECTION 3 GENERAL CONTRACTOR'S MONTHLY STATUS REPORT
WORK-SHEET

Reporting Period: _____

Contact Person: _____

Date Submitted: _____

Telephone: _____

Project Name	Contract Dollar Amount	Sub-Contractor	Start Date	Scheduled Completion Date	Total Hours Worked	Total New Hires	Total Section 3 New Hires	% of Section 3 Hours Worked	Total Contract Dollars to Section 3 Labor

Signature _____ Date: _____

Return with monthly activity report/pay request

SECTION 3 SUB-CONTRACTOR MONTHLY REPORT

SUPPLEMENTAL INFORMATION

1. Reporting Period:	
<div style="border: 1px solid black; width: 100%; height: 30px; margin-bottom: 5px;"></div> 2. Project Name	<div style="border: 1px solid black; width: 100%; height: 30px; margin-bottom: 5px;"></div> 3. Project Location

(4)	(5)	(6)	(7)	(8)	(9)
Job Category	Total New Hires	Total New Hires that are Section 3 Residents	Total Staff Hours	Total Staff hours for Section 3 Employees & Trainees	Total Section 3 Labor Dollars
Professionals					
Professionals					
Technical					
Office/Clerical					
Trade:					
Trade:					
Trade:					
Trade:					
Trade:					
Trade:					
Trade:					
Trade:					
Trade:					
Trade:					
Trade:					
(9) TOTAL		0			

Signature _____ Date: _____

Include in monthly activity report/pay request (Sub-contractors submit to General)